



**Pacific Gas and
Electric Company**

David H. Oatley
Vice President and
General Manager

Diablo Canyon Power Plant
PO Box 56
Avila Beach, CA 93424

805 545 4350
Fax 805 545 4234

April 30, 2003

PG&E Letter DCL-03-049

U.S. Nuclear Regulatory Commission
ATTN: Document Control Desk
Washington, DC 20555-0001

Docket No. 50-275, OL-DPR-80
Docket No. 50-323, OL-DPR-82
Diablo Canyon Units 1 and 2
2002 Annual Radioactive Effluent Release Report

Dear Commissioners and Staff:

PG&E is submitting the enclosed 2002 Annual Radioactive Effluent Release Report in accordance with 10 CFR 50.36a (a)(2) and Section 5.6.3 of the Diablo Canyon Power Plant Technical Specifications.

The report describes the quantities of radioactive gaseous and liquid effluents released from the plant, and the solid radioactive waste shipments made during the period of January 1 through December 31, 2002.

One compact disk is being sent with the report. The disk contains meteorological data. If you have any questions, please contact Jeff Gardner of my staff at (805) 545-4385.

Sincerely,

David H. Oatley

swh/3649/R0232137

Enclosure

cc/enc: Edgar D. Bailey, DHS
Roger W. Briggs
Harvey Collins
Ellis W. Merschoff
William A. Nestel
David L. Proulx
Girija S. Shukla
Gregory Thomas
Diablo Distribution

IE48
A009

SUBMITTAL PROCESSING CHECKLIST

PG&E Letter No. (e.g., DCL, DIL, etc.) | **DCL 03-049**

Subject: **2002 Annual Radioactive Effluent Release Report**

Target Submittal Date 28 APR 2003 Firm Submittal Date: 30 APR 2003 N/A

File Location: S:\RS\ RA\2002 Annual RERR Report Rev 1.doc

	Initial	/		Date
1. References & bases identified for factual information.	sw	/		4/25
2. Outgoing Correspondence Screen (RS-2) completed & commitments captured per XI4.ID1.	sw	/		4/25
3. RS Manager's concurrence for release obtained.	sw	/		4/25
4. Record of Review Checklist completed & signed per XI1.ID1.	sw	/		4/25
5. Clerical reviews completed. Draft # _____ / _____ Draft # _____ / _____ Final (on signatory letterhead)				<u>Km</u> / <u>4/29</u>
6. Peer Review Checklist (RS-4) completed				<u>sw</u> / <u>4.29</u>
7. Provide this checklist, the final letter & enclosures, Record of Review Checklist, & Outgoing Correspondence Screen to signatory. • For FIRM submittals, was 2 days met? Yes <input checked="" type="checkbox"/> No <input type="checkbox"/> N/A <input type="checkbox"/>	sw	/		4/25
8. Will entire submittal, including enclosures, be placed in RS & ACTS libraries and EDMS? If NO , complete form RS-1A, indicating where the enclosures, etc. will be maintained. Yes <input type="checkbox"/> No <input checked="" type="checkbox"/>	sw	/		4/25
9. Indicate RMS access level. Check one box only. [X] Reg Regular [] "D" Proprietary [] "B" Personnel Record [] "A" Security Safeguards Information (SSI) • RMS folder name _____ (i.e., LAR, LER, etc.) • Put in envelope with a copy of this form attached on outside and put in SSI safe in RS Manager's office.				sw / 4/25
10. Place copy of this checklist (including RS-1A, if applicable), the submittal & enclosures, Record of Review Checklist, & the Outgoing Correspondence Screen in the RMS (fireproof) file cabinet (or the SSI safe, if applicable).				<u>sw</u> / <u>4.30</u>
11. Deliver this checklist (including RS-1A, if applicable), original of signed submittal & enclosures, Outgoing Correspondence Screen, & Record of Review Checklist to clerks.				<u>sw</u> / <u>4.30</u>
12. Tracking documents (i.e., NCR ACTs or AEs) have been updated for submittal completion (including the LERtemplate.ppt, if the submittal is an LER). N/A <input checked="" type="checkbox"/> • LERtemplate.ppt is located at S:\RS\DCISC\LERs\LERtemplateYYYY.ppt				/
13. Verify commitment entry on NCR ACTs or AEs within 15 days. N/A <input checked="" type="checkbox"/>				/

SUBMITTAL PROCESSING CHECKLIST – Supplement

Identify the enclosures, etc. (e.g., proprietary, personal, or SSI) that will **NOT** be filed in the RS and ACTS libraries, or EDMS, and where the actual documents will be maintained.

Examples:

Enclosure 1 (Personal information)	NRC 396 forms are retained by Learning Services and the DCPD Medical Facility.
Enclosure 3 (Diskette)	The diskettes are maintained by Radiation Protection.
Entire Document	The complete proprietary version of this document is available in the PG&E Law Department in San Francisco.

Item	Location
Enclosure: TES Meteorological Data: CD-R	Data maintained by TES in San Ramon
Attachment 1: PD CY2, Rev 5	Maintained in EDMS
Attachment 2: IDAP CY2.ID1, Rev. 6A	Maintained in EDMS
Attachment 3: CAP A-8, Rev. 26	Maintained in EDMS
Attachment 4: DLAP RP2.DC2, Rev. 12 ¹¹ <i>sl</i>	Maintained in EDMS
Attachment 5: DLAP RP2.DC3, Rev. 8 ⁵ <i>sl</i>	Maintained in EDMS

NUCLEAR POWER GENERATION
XII.ID1
ATTACHMENT 8.1

TITLE: Regulatory Submittal - Record of Review Checklist

SUBMITTAL TITLE 2002 ANNUAL RADIOACTIVE EFFLUENT RELEASE REPORT

REQUIRED SUBMITTAL DATE: 30 APR 2003 N/A **SCHEDULED SUBMITTAL DATE:** 28 APR 2003

<u>PRIMARY REVIEWERS</u>	NAME	COMMENTS		RESOLVED	
		YES	NO	YES	NO
LEAD TECHNICAL REVIEWER	<u>JOHN KNEMBYER</u>	<input type="checkbox"/>	<input checked="" type="checkbox"/>	<input type="checkbox"/>	<input type="checkbox"/>
LEAD TECHNICAL DIRECTOR/MGR	<u>LANCE HOPKINS / BOB WITE</u>	<input checked="" type="checkbox"/>	<input checked="" type="checkbox"/>	<input checked="" type="checkbox"/>	<input type="checkbox"/>
LICENSING MANAGEMENT	<u>STAR KETELSEN</u>	<input type="checkbox"/>	<input checked="" type="checkbox"/>	<input type="checkbox"/>	<input type="checkbox"/>
INDEPENDENT TECH REVIEWER	<u>JEFF GARDNER / DAVID CROFT</u>	<input checked="" type="checkbox"/>	<input type="checkbox"/>	<input checked="" type="checkbox"/>	<input type="checkbox"/>
CROSS-DISCIPLINE REVIEWER(S)		<input type="checkbox"/>	<input type="checkbox"/>	<input type="checkbox"/>	<input type="checkbox"/>
<input type="checkbox"/> OPERATIONS		<input type="checkbox"/>	<input type="checkbox"/>	<input type="checkbox"/>	<input type="checkbox"/>
<input type="checkbox"/> MAINTENANCE		<input type="checkbox"/>	<input type="checkbox"/>	<input type="checkbox"/>	<input type="checkbox"/>
<input type="checkbox"/> ENGINEERING		<input type="checkbox"/>	<input type="checkbox"/>	<input type="checkbox"/>	<input type="checkbox"/>
<input type="checkbox"/> PLANT SUPPORT		<input type="checkbox"/>	<input type="checkbox"/>	<input type="checkbox"/>	<input type="checkbox"/>
<input type="checkbox"/> QUALITY		<input type="checkbox"/>	<input type="checkbox"/>	<input type="checkbox"/>	<input type="checkbox"/>
<input type="checkbox"/> LAW		<input type="checkbox"/>	<input type="checkbox"/>	<input type="checkbox"/>	<input type="checkbox"/>
<input type="checkbox"/> TES		<input type="checkbox"/>	<input type="checkbox"/>	<input type="checkbox"/>	<input type="checkbox"/>
<input type="checkbox"/> CHEMISTRY & ENVIRONMENTAL		<input type="checkbox"/>	<input type="checkbox"/>	<input type="checkbox"/>	<input type="checkbox"/>
OPERATIONS		<input type="checkbox"/>	<input type="checkbox"/>	<input type="checkbox"/>	<input type="checkbox"/>
<input type="checkbox"/> PSRC		<input type="checkbox"/>	<input type="checkbox"/>	<input type="checkbox"/>	<input type="checkbox"/>
<input type="checkbox"/> NSOC		<input type="checkbox"/>	<input type="checkbox"/>	<input type="checkbox"/>	<input type="checkbox"/>
<input type="checkbox"/> OTHER		<input type="checkbox"/>	<input type="checkbox"/>	<input type="checkbox"/>	<input type="checkbox"/>

<u>SECONDARY REVIEWERS</u>	NAME	COMMENTS		RESOLVED	
		YES	NO	YES	NO
LAW		<input type="checkbox"/>	<input type="checkbox"/>	<input type="checkbox"/>	<input type="checkbox"/>
	<u>CLIFT MILLER</u>	<input checked="" type="checkbox"/>	<input type="checkbox"/>	<input checked="" type="checkbox"/>	<input type="checkbox"/>
	<u>MARTIN WRIGHT</u>	<input type="checkbox"/>	<input type="checkbox"/>	<input type="checkbox"/>	<input type="checkbox"/>
		<input type="checkbox"/>	<input type="checkbox"/>	<input type="checkbox"/>	<input type="checkbox"/>
		<input type="checkbox"/>	<input type="checkbox"/>	<input type="checkbox"/>	<input type="checkbox"/>
		<input type="checkbox"/>	<input type="checkbox"/>	<input type="checkbox"/>	<input type="checkbox"/>
		<input type="checkbox"/>	<input type="checkbox"/>	<input type="checkbox"/>	<input type="checkbox"/>

CONCURRENCE HAS BEEN RECEIVED FROM PRIMARY REVIEWERS AND TECHNICAL COMMENTS HAVE BEEN RESOLVED

LEAD LICENSING ENGINEER: 

DATE: 4.28.2003

**PEER REVIEW CHECKLIST
LICENSING SUBMITTAL**
(To be performed on final draft only.)

PG&E Letter No. (e.g., DCL, DIL, etc.) | DCL-03-049

ITEM	DESCRIPTION	INITIALS*
Cover Letter	Correct signatory letterhead (Ref. XI1.ID2)	DSM
	Full names used for signatory & cc list; right people listed	DSM
	Title correct	DSM
	Letter number verified against outgoing correspondence log	DSM
	Letter number appears on all pages	DSM
	All pages numbered, except first page	DSM
	Date correct and appears on all pages (month, day, and year)	DSM
	Address and docket number(s) correct	DSM
	Text reviewed for obvious errors	DSM
	TS and/or 10 CFR references correct	DSM
	If affidavit required or NOV response, verify Law Department has reviewed	DSM
All Submittals	Text reviewed for obvious errors	DSM
	Revision bars included (if applicable)	N/A
	TS and/or 10 CFR references correct	DSM
	References to other documents correct (e.g., DCLs, FSAR, etc.)	DSM
	Submittal addresses the specific regulation requirements	DSM
	Enclosures labeled	DSM
Outgoing Correspondence Screen (RS-2)	Letter number and title correct	DSM
	FSAR Update Review – one box checked.	DSM
	Commitment implemented before or after LA receipt (LARs/RAIs only)	N/A
	Commitment(s) quoted verbatim (& clarifications made if needed)	N/A
	Tracking Document - AR/AE or NCR Action numbers	N/A
	Assigned To - Name & Organization Code	N/A
	Commitment Type - Firm or Target & Due Date	N/A
	Outage Commitment - Y or N indicator & Applicable Outage	N/A
	PCD Commitment - Y or N indicator & Implementing Documents	N/A
	Duplicate of NCR Commitment in NCR - Y or N indicator & PCD number	N/A
	An individual from all departments assigned commitments was a Cross-Discipline Reviewer (Ref. XI1.ID1, Step 5.2.3.a 4.a)	N/A
LER Forms	LER number correct; consistent with cover letter	N/A
	LER number & docket number(s) on first & remaining pages	N/A
	Title consistent with cover letter & Outgoing Correspondence Screen (RS-2)	N/A
	Dates correct on first page header (month, day, & year)	N/A
	Dates & times consistent with 10 CFR 50 72 ENS reports made	N/A
	Dates & times consistent with other source documents	N/A
	Dates & times consistent between abstract and narrative	N/A
	Page numbers correct & all pages accounted for	N/A
	Abstract word count <1400 characters (including spaces)	N/A
IEEE 803 codes entered and correct	N/A	
Procedure Submittals	Procedure revision numbers current using EDMS (e.g., EPIP)	N/A
Filing Instructions	Filing instructions clear (Per RS-1A, if applicable)	N/A
ROR Checklist	Record of Review Checklist completed and signed	DSM
Final Draft	All discrepancies resolved with Lead Licensing Engineer	DSM

* Enter N/A where not applicable.

I have reviewed this submittal for the items initialed above. This submittal is ready for the signatory.
Donald O. Moore Performed by 4/28/03 Date

bcc/enc*: David C. Chen
Jeffery E. Gardner
John R. Knemeyer
Robert W. Lorenz

* To save some paper, bcc's should receive the enclosure without attachments 1-5 (copies of DCPD procedures).

OUTGOING CORRESPONDENCE SCREEN
(Remove prior to NRC submittal)

Document: PG&E Letter DCL-03-049
Subject: 2002 Annual Radioactive Effluent Release Report
File Location S:\CHEM\SECURE\Annual Rad Eff Report\2002\2002 Annual
Report Draft Rev 1.DOC
Version:

FSAR Update Review

Utilizing the guidance in XI3.ID2, does the FSAR Update need to be revised? Yes No
If "Yes", submit an FSAR Update Change Request in accordance with XI3.ID2 (or if this is an LAR, process in accordance with WG-9)

Commitment #1
Statement of Commitment: NONE

**DIABLO CANYON POWER PLANT
2002 ANNUAL RADIOACTIVE EFFLUENT RELEASE REPORT**



January 1 - December 31, 2002



DIABLO CANYON POWER PLANT

Annual Radioactive Effluent Release Report
January 1, 2002 Through December 31, 2002

Table of Contents

Introduction.....	3
I. Supplemental Information	4
II. Major Changes to Liquid, Gaseous, and Solid Radwaste Systems	10
III. Changes to Radiological Monitoring and Controls Program (RMCP).....	10
IV. Changes to the Radioactive Effluent Controls Program (RECP).....	10
V. Changes to the Off-Site Dose Calculation Procedure (ODCP)	10
VI. Changes to the Process Control Program (PCP).....	11
VII. Land Use Census	11
VIII. Gaseous and Liquid Effluents	12
TABLE 1 – GASEOUS EFFLUENTS – SUMMATION OF ALL RELEASES	12
TABLE 2 – GASEOUS EFFLUENTS – GROUND-LEVEL RELEASES.....	15
TABLE 3 – GASEOUS EFFLUENTS – LOWER LIMITS OF DETECTION.....	19
TABLE 4 – LIQUID EFFLUENTS – SUMMATION OF ALL RELEASES.....	21
TABLE 5 – LIQUID EFFLUENTS – NUCLIDES RELEASED	24
TABLE 6 – LIQUID EFFLUENTS – LOWER LIMIT OF DETECTION (LLD)	30
IX. Solid Radwaste Shipments	33
X. Radiation Dose due to Gaseous and Liquid Effluents.....	36
TABLE 7 – RADIATION DOSE DUE TO THE RELEASE OF RADIOACTIVE LIQUID EFFLUENTS.....	38
TABLE 8 – RADIATION DOSE DUE TO THE RELEASE OF RADIOACTIVE GASEOUS EFFLUENTS	39
TABLE 9 – PERCENT OF TECHNICAL SPECIFICATION LIMITS FOR RADIOACTIVE LIQUID EFFLUENTS.....	42
TABLE 10 – PERCENT OF TECHNICAL SPECIFICATION LIMITS FOR RADIOACTIVE GASEOUS EFFLUENTS.....	43
TABLE 11 – ON-SITE DOSE TO MEMBERS OF THE PUBLIC.....	45
XI. Meteorological Data	50

DIABLO CANYON POWER PLANT

**Annual Radioactive Effluent Release Report
January 1, 2002 Through December 31, 2002**

Attachments

1. Radiological Monitoring and Controls Program (RMCP), CY2 Revision 5
2. Radioactive Effluent Controls Program (RECP), CY2.ID1 Revision 6A
3. Off-Site Dose Calculation Procedure (ODCP), CAP A-8 Revision 26
4. Radwaste Solidification Process Control Program (PCP), RP2.DC2 Revision 11
(incorporates revision 8-11)
5. Radwaste Dewatering Control Program, RP2.DC3 Revision 5
6. 2002 Land Use Census

DIABLO CANYON POWER PLANT

2002 Annual Radioactive Effluent Release Report

Introduction

The 2002 Annual Radioactive Effluent Release Report summarizes gaseous and liquid effluent releases from Diablo Canyon Power Plant's (DCPP) Units 1 and 2. The report includes the dose due to release of radioactive liquid and gaseous effluents and summarizes solid radwaste shipments. The report contains information required by Units 1 and 2 Technical Specification (TS) 5.6.3 and is presented in the general format of Regulatory Guide 1.21, "Measuring, Evaluating, and Reporting Radioactivity in Solid Wastes and Releases of Radioactive Materials in Liquid and Gaseous Effluents from Light-Water Nuclear Power Plants," Appendix B, "Effluent and Waste Disposal Report." Procedure revisions, which implement the Radiological Monitoring and Controls Program (RMCP), Radioactive Effluent Controls Procedure (RECP), Off-Site Dose Calculation Procedure (ODCP), and Process Control Program (PCP), and one compact disk containing meteorological data, are attached.

In all cases, the plant effluent releases were well below TS limits for the report period.

I. Supplemental Information

A. Regulatory Limits

1. Gaseous Effluents

a. Noble Gas Dose Rate Limit

The dose rate in areas at or beyond the site boundary due to radioactive noble gases released in gaseous effluents is limited to less than or equal to 500 millirem (mR) per year to the total body and less than or equal to 3000 mR per year to the skin. (Radioactive Effluent Controls Program 6.1.6.1.a.)

b. Particulate and Iodine Dose Rate Limit

The dose rate in areas at or beyond the site boundary due to iodine-131, iodine-133, tritium, and all radionuclides in particulate form with half lives greater than 8 days in gaseous effluents, is limited to less than or equal to 1500 mR per year to any organ. (RECP 6.1.6.1.b)

c. Noble Gas Dose Limit

The air dose due to noble gases released in gaseous effluents from each reactor unit to areas at or beyond the site boundary is limited to the following:

Radiation Type	Calendar Quarter Limit RECP 6.1.7.1.a	Calendar Year Limit RECP 6.1.7.1.b
Gamma	5 millirad	10 millirad
Beta	10 millirad	20 millirad

d. Particulate and Iodine Dose Limit

The dose to an individual from iodine-131, iodine-133, tritium, and all radionuclides in particulate form with half lives greater than 8 days in gaseous effluents released from each reactor unit to areas at or beyond the site boundary is limited to less than or equal to 7.5 mR to any organ in any calendar quarter and less than or equal to 15 mR to any organ during a calendar year. (RECP 6.1.8.1)

2. Liquid Effluents

a. Concentration

The concentration of radioactive material released from the site is limited to the concentrations specified in 10 CFR Part 20, Appendix B, Table 2, Column 2, for radionuclides other than dissolved or entrained noble gases. For dissolved or entrained noble gases, the concentration is limited to 2×10^{-4} microcuries/milliliter ($\mu\text{Ci/ml}$) total activity. (RECP 6.1.3.1)

b. Dose

The dose or dose commitment to a member of the public from radioactive materials in liquid effluents released from each reactor unit to areas at or beyond the site boundary is limited to the following:

Dose Type	Calendar Quarter Limit RECP 6.1.4.1.a	Calendar Year Limit RECP 6.1.4.1.b
Total Body	1.5 millirem	3 millirem
Any Organ	5 millirem	10 millirem

B. Maximum Permissible Concentrations

1. Gaseous Effluents

Maximum permissible concentrations are not used for determining allowable release rates for gaseous effluents at DCCP.

2. Liquid Effluents

The concentrations listed in 10 CFR 20, Appendix B, Table 2, Column 2, for radionuclides other than dissolved or entrained noble gases are used for determining the allowable release concentration at the point of discharge from the site for liquid effluents. For dissolved or entrained noble gases, the allowable release concentration at the point of discharge is limited to 2×10^{-4} $\mu\text{Ci/ml}$ total activity for liquid effluents.

C. Measurements and Approximations of Total Radioactivity

1. Gaseous Effluents

a. Fission and Activation Gases

A pair of off-line monitors equipped with beta scintillator detectors monitors the gaseous radioactivity released from the plant vent. The monitor readings are correlated to isotopic concentration based on laboratory isotopic analysis of grab samples using a germanium detector.

For plant vent noble gas releases, grab sample results are used to quantify releases. The individual batch release data are used to quantify the radioactivity discharged from the gas decay tanks and containment.

A noble gas grab sample is obtained and analyzed at least weekly. The isotopic mixture is assumed to remain constant between grab sample analyses.

Containment purges, gas decay tank releases, and air ejector discharges are released via the plant vent.

The gaseous radioactivity released from the steam generator blowdown tank vent is measured by analyzing liquid or steam condensate grab samples with a germanium detector. A factor R, a ratio of unit masses between water flashing to steam and water entering the tank, is used to calculate the activity. The isotopic concentrations are assumed to remain constant between grab samples.

Other potential pathways for releasing gaseous radioactivity are periodically monitored by collecting grab samples and analyzing these samples with a germanium detector system.

b. Iodines

Radioiodines released from the plant vent are monitored by continuous sample collection on silver zeolite cartridges. The cartridges are changed at least weekly and analyzed with a germanium detector. The radioiodine releases are averaged over the period of cartridge sample collection.

Other potential pathways for releasing radioiodines are periodically monitored by collecting samples using charcoal or silver zeolite cartridges and analyzing with a germanium detector.

Radioactive materials in particulate form released from the plant vent are monitored by continuous sample collection on particulate filters. The filters are changed at least weekly and analyzed with a germanium detector. The particulate radioactivity is averaged over the period of particulate filter sample collection. Each filter is analyzed for alpha emitters using an internal proportional counter. Plant vent particulate filters collected during a quarter are used for the composite analysis for strontium-89 and -90, which is counted on an internal proportional counter after chemical separation.

Other potential pathways for releasing radioactive particulate are periodically monitored by collecting samples using particulate filters and analyzing these filters with a germanium detector.

c. Tritium

Tritium released from the plant vent is monitored by passing a measured volume of plant vent sample through a water column and determining the tritium increase in the water. An aliquot of the water is counted in a liquid scintillation spectrometer. The minimum routine sample frequency for tritium is weekly. The tritium concentration is assumed to remain constant between samples.

d. Estimations of Overall Error

Sources of error considered for batch release are: (1) calibration source; (2) calibration counting; (3) sampling; (4) sample counting; and (5) gas decay tank pressure gauge / containment exhaust fan flow rate.

Sources of error for continuous release are: (1) calibration source; (2) calibration counting; (3) sampling; (4) sample counting; (5) process monitor (RE-14) reading (fission gases only); and (6) plant vent exhaust fan flow rate.

$$\text{Total error} = (\sigma^2_1 + \sigma^2_2 + \sigma^2_3 + \dots + \sigma^2_i)^{1/2}$$

Where σ_i = error associated with each component

2. Liquid Effluents

a. Batch Releases

Each tank of liquid radwaste is analyzed for principal gamma emitters using a germanium detector prior to release. A monthly prerelease analysis includes dissolved and entrained gases. Volume proportional monthly and quarterly composites are prepared from aliquots of each tank volume discharged. The monthly composite is analyzed for tritium using a liquid scintillation spectrometer and gross alpha radioactivity using an internal proportional counter. The quarterly composite is analyzed for iron-55 using a liquid scintillation spectrometer and for strontium-89 and -90 using an internal proportional detector following chemical separations.

b. Continuous releases

For the continuous liquid releases of the steam generator blowdown tank and turbine building sump oily water separator, daily grab samples are collected and aliquots are proportioned for weekly, monthly, and quarterly composites.

The oily water separator weekly composite is analyzed for principal gamma emitters using a germanium detector. The steam generator blowdown tank weekly composite is analyzed for principal gamma emitters and iodine-131.

The steam generator blowdown tank monthly composite is analyzed for tritium using a liquid scintillation spectrometer and for gross alpha using an internal proportional counter.

The steam generator blowdown tank quarterly composite is analyzed for iron-55 using a liquid scintillation spectrometer and for strontium-89 and strontium-90 using an internal proportional counter following chemical separation. The results for each of the composites are averaged over the period of the composite.

In addition, one grab sample of the steam generator blowdown tank is analyzed monthly for dissolved and entrained gases using a germanium detector. The results of this analysis are assumed to remain constant over the period of one month.

A grab sample of the steam generator blowdown is collected at least weekly and analyzed for gamma activity using a germanium detector. This analysis is used to monitor activity, however, is not used in effluent calculations unless a significant change is detected.

Note on dilution volume:

Tables 4A, 4B and 4C, "Liquid Effluents - Summation Of All Releases," item F., lists the "Volume of circulating saltwater used during release periods" in liters. This value is calculated by multiplying the discharge duration by the circulating water flow rate. The values listed in the Tables are the summation of the circulating water discharge volume calculated for each individual batch and continuous discharge period. Therefore, in the case where two or more simultaneous discharges into the same circulating water are occurring, the calculated volume of circulating water is duplicated, and therefore the sum of the dilution volumes for the batch releases and continuous releases are greater than the actual dilution volume since each discharge incorporates the circulating discharge flow rate in its own dose calculation.

c. Estimation of Overall Error

Sources of error considered are: (1) calibration source error; (2) calibration counting error; (3) sampling error; (4) sample counting error; and (5) volume of waste release error.

These sources of error are independent; therefore the total error is calculated according to the following formula:

$$\text{Total error} = (\sigma^2_1 + \sigma^2_2 + \sigma^2_3 + \dots + \sigma^2_i)^{1/2}$$

Where σ_i = error associated with each component

D. Batch Releases

1. Liquid

a. Number of batch releases.....	613
b. Total time period for batch releases.....	2870 hours
c. Maximum time period for a batch release.....	168 hours
d. Average time period for a batch release.....	4.68 hours
e. Minimum time period for a batch release.....	0.02 hours
f. Average saltwater flow during batch releases.....	9.27E+05 GPM

2. Gaseous

a. Number of batch releases.....	130
b. Total time period for batch releases.....	1608 hours
c. Maximum time period for a batch release.....	72 hours
d. Average time period for a batch release.....	12.37 hours
e. Minimum time period for a batch release.....	1.00 hours

E. Abnormal Release (Gaseous and Liquid)

1. Leakage of waste gas from the Waste Gas Header occurred between 10/11/02 – 10/13/02. The gas leaked through the boric acid evaporator system into the Auxiliary Building, and eventually through the Plant Vent. The leak in the boric acid evaporator system was isolated to stop the un-planned, monitored discharge.

The release rate of noble gas to the plant vent resulted in 0.58% of the release rate limit. The resulting gamma air dose and beta air dose from this discharge was 1.42E-3 mrad and 4.99E-4 mrad, respectively.

2. An unplanned, monitored discharge was made from the Waste Handling And Treatment system. A valve alignment was made that allowed water from one of the tanks to inadvertently discharge.

The radioactive concentration of the discharged water was $6.01E-5$ $\mu\text{Ci/ml}$. The effluent concentration limit for this discharge was $2.55E-4$ $\mu\text{Ci/ml}$. Therefore, the discharge was below the discharge limit.

The total body dose for this discharge was $1.84E-8$ mrem. The highest organ dose was $3.17E-6$ mrem (thyroid).

3. The Liquid Radwaste (LRW) monthly composite sample for June 2002 was analyzed for gross alpha. The analysis result was $<1.19E-7$ $\mu\text{Ci/ml}$. The required lower limit of detector for this analysis is $1.0E-7$ $\mu\text{Ci/ml}$. Therefore, the value included in this report is listed as $1.19E-7$ $\mu\text{Ci/ml}$. This is reflected on Tables 4A and 4C, Section D.
4. A summation error was identified on Table 4D, Section D. The "Annual Total" curie value for Liquid Effluent Gross Alpha only reflected the Second Quarter value from Table 4A. The summation for this report (2002 data) is correct. Any corrections to previous year's reports due to this error will be included in next year's Annual report.

II. Major Changes to Liquid, Gaseous and Solid Radwaste Treatment System

There were no major changes to liquid, gaseous, and solid radwaste treatment systems during the report period.

III. Changes to the RMCP

CY2, "Radiological Monitoring And Controls Program," was revised during the report period.

Revision 5 made the following changes:

- Changed the frequency of the Radioactive Effluents Controls Program audits from 12 months to 24 months to reflect a recent change in the FSAR.
- Updated the procedure to convert position titles to a generic format.

Revision 5 was reviewed by the Station Director on September 25, 2002, and approved by the Chief Nuclear Officer on October 2, 2002. (See Attachment 1)

IV. Changes to the RECP

CY2.ID1, "Radioactive Effluents Controls Program," was revised during the report period.

Revision 6A was a minor editorial correction that did not change the technical content of the procedure. This change was effective on February 1, 2002. The change did not require review or approval from the Station Director. (see Attachment 2)

V. Changes to the ODCP

CAP A-8, "Off-Site Dose Calculations Procedure," was revised. Revision 26 made the following change:

- Updated the gaseous effluent dispersion and deposition values (X/Q and D/Q) based upon the most recent 5 year average annual meteorological conditions.

Revision 26 was reviewed by the PSRC and approved by the Station Director on May 31, 2002. (See Attachment 3)

VI. Changes to the Process Control Program

RP2.DC2, "Process Control Program," was revised five times during the report period.

A. Revision 8 made the following change:

- The title cited in the procedure for this annual report.
- The Station Director approved revision 8 on March 25, 2002.

B. Revision 9 made the following change:

- Advance polymer solidification agent was added to the process control program.
- The Station Director approved revision 9 on July 3, 2002.

C. Revision 10 made the following change:

- The advanced polymer was altered from a 4-component to a 3-component mixture to achieve an extended gelation time.
- The Station Director approved revision 10 on September 30, 2002.

D. Revision 11 made the following change:

- An altered 4-component polymer was adopted for extended gelation based upon a specimen result of the 3-component mix.
- The Station Director approved revision 11 on October 17, 2002. (See Attachment 4)

RP2.DC3, "Dewatering Control Procedure" was revised once during the report period.

A. Revision 5 made the following change:

- Allows Class A waste above 1 μ Ci/cc to be loaded into steel liners, versus HICs. This matches the new trench at the Envirocare site.
- The Station Director approved revision 5 on February 8, 2002. (See Attachment 5)

VII. Land Use Census

Changes to the Land Use Census Program are included as Attachment 6.

VIII. Gaseous and Liquid Effluents

Tables 1 through 3 describe gaseous effluents. Tables 4 through 6 describe liquid effluents.

**DIABLO CANYON POWER PLANT
ANNUAL RADIOACTIVE EFFLUENT RELEASE REPORT 2002**

**TABLE 1A
GASEOUS EFFLUENTS - SUMMATION OF ALL RELEASES**

Units	First Quarter	Second Quarter	Est.Total Error %
-------	------------------	-------------------	----------------------

A. Fission and activation gases

1. Total release	Ci	1.08E+1	1.52E+0	46%
2. Average release rate for period	μCi/sec	1.39E+0	1.93E-1	
3. Percent of technical specification limit ¹	%	3.57E-3	1.40E-3	

B. Iodines

1. Total iodine-131	Ci	1.71E-4	1.76E-5	24%
2. Average release rate for period	μCi/sec	2.20E-5	2.24E-6	
3. Percent of technical specification limit ¹	%	1.31E-4	1.33E-5	

C. Particulates

1. Particulates with half-lives >8 days	Ci	5.04E-4	2.65E-4	24%
2. Average release rate for period	μCi/sec	6.48E-5	3.37E-5	
3. Percent of technical specification limit ¹	%	2.35E-5	1.37E-5	
4. Gross alpha radioactivity	Ci	4.46E-7	1.35E-7	

D. Tritium

1. Total release	Ci	3.09E+1	1.13E+2	13%
2. Average release rate for period	μCi/sec	3.97E+0	1.44E+1	
3. Percent of technical specification limit ¹	%	9.33E-6	3.38E-5	

MDA = Less than the "a posteriori" minimum detectable activity (microcuries per unit mass or volume). This note applies to all tables.

¹ RECP 6.1.6.1 Limit

**DIABLO CANYON POWER PLANT
ANNUAL RADIOACTIVE EFFLUENT RELEASE REPORT 2002**

**TABLE 1B
GASEOUS EFFLUENTS - SUMMATION OF ALL RELEASES**

Units	Third Quarter	Fourth Quarter	Est.Total Error %
-------	------------------	-------------------	----------------------

A. Fission and activation gases

1. Total release	Ci	7.58E-1	3.72E+0	46%
2. Average release rate for period	μCi/sec	9.54E-2	4.68E-1	
3. Percent of technical specification limit ¹	%	1.11E-4	1.20E-3	

B. Iodines

1. Total iodine-131	Ci	5.50E-5	2.12E-3	24%
2. Average release rate for period	μCi/sec	6.92E-6	2.67E-4	
3. Percent of technical specification limit ¹	%	1.46E-5	1.51E-3	

C. Particulates

1. Particulates with half-lives >8 days	Ci	2.35E-5	1.25E-4	24%
2. Average release rate for period	μCi/sec	2.96E-6	1.57E-5	
3. Percent of technical specification limit ¹	%	1.20E-6	5.24E-6	
4. Gross alpha radioactivity	Ci	MDA	MDA	

D. Tritium

1. Total release	Ci	5.18E+1	1.11E+2	13%
2. Average release rate for period	μCi/sec	6.51E+0	1.40E+1	
3. Percent of technical specification limit ¹	%	1.53E-5	3.28E-5	

MDA = Less than the "a posteriori" minimum detectable activity (microcuries per unit mass or volume). This note applies to all tables.

¹ RECP 6.1.6.1 Limit

**DIABLO CANYON POWER PLANT
 ANNUAL RADIOACTIVE EFFLUENT RELEASE REPORT 2002
 TABLE 1C
 GASEOUS EFFLUENTS - SUMMATION OF ALL RELEASES**

Units	Annual Total
-------	--------------

A. Fission and activation gases

1. Total release	Ci	1.68E+1
2. Average release rate for period	μCi/sec	5.33E-1
3. Percent of technical specification limit ¹	%	1.56E-3

B. Iodines

1. Total iodine-131	Ci	2.37E-3
2. Average release rate for period	μCi/sec	7.50E-5
3. Percent of technical specification limit ¹	%	4.19E-4

C. Particulates

1. Particulates with half-lives >8 days	Ci	9.17E-4
2. Average release rate for period	μCi/sec	2.91E-5
3. Percent of technical specification limit ¹	%	1.08E-5
4. Gross alpha radioactivity	Ci	5.81E-7

D. Tritium

1. Total release	Ci	3.07E+2
2. Average release rate for period	μCi/sec	9.74E+0
3. Percent of technical specification limit ¹	%	2.29E-5

¹ RECP 6.1.6.1 Limit

**DIABLO CANYON POWER PLANT
ANNUAL RADIOACTIVE EFFLUENT RELEASE REPORT 2002**

**TABLE 2A
GASEOUS EFFLUENTS - GROUND LEVEL RELEASES**

Nuclides Released	Units	First Quarter		Second Quarter	
		Continuous Mode	Batch Mode	Continuous Mode	Batch Mode

1. Fission gases

argon-41	Ci	2.54E+0	4.44E-2	MDA	1.13E+0
krypton-85	Ci	MDA	2.00E-1	MDA	2.40E-1
krypton-85m	Ci	MDA	MDA	MDA	MDA
krypton-87	Ci	MDA	MDA	MDA	MDA
krypton-88	Ci	MDA	MDA	MDA	MDA
xenon-131m	Ci	MDA	MDA	MDA	7.52E-4
xenon-133	Ci	8.01E+0	2.23E-2	MDA	1.47E-1
xenon-133m	Ci	MDA	MDA	MDA	7.64E-4
xenon-135	Ci	MDA	4.30E-5	MDA	7.78E-5
xenon-135m	Ci	MDA	MDA	MDA	MDA
xenon-138	Ci	MDA	MDA	MDA	MDA
TOTAL FOR PERIOD	Ci	1.06E+1	2.67E-1	MDA	1.52E+0

2. Iodines

iodine-131	Ci	1.71E-4
iodine-133	Ci	MDA
iodine-135	Ci	MDA
TOTAL FOR PERIOD	Ci	1.71E-4

1.76E-5
MDA
MDA
1.76E-5

MDA = Less than the "a posteriori" minimum detectable activity (microcuries per unit mass or volume). This note applies to all tables.

**DIABLO CANYON POWER PLANT
ANNUAL RADIOACTIVE EFFLUENT RELEASE REPORT 2002
TABLE 2A (Continued)
GASEOUS EFFLUENTS - GROUND LEVEL RELEASES**

Nuclides Released	Units	Continuous Mode	
		First Quarter	Second Quarter

3. Particulates

barium-140	Ci	MDA	MDA
cesium-134	Ci	MDA	MDA
cesium-137	Ci	2.97E-4	MDA
cerium-141	Ci	MDA	MDA
cerium-144	Ci	MDA	MDA
chromium-51	Ci	MDA	MDA
cobalt-57	Ci	MDA	MDA
cobalt-58	Ci	2.06E-4	2.65E-4
cobalt-60	Ci	MDA	MDA
iron-59	Ci	MDA	MDA
lanthanum-140	Ci	MDA	MDA
manganese-54	Ci	MDA	MDA
molybdenum-99	Ci	MDA	MDA
ruthenium-103	Ci	MDA	MDA
strontium-89	Ci	MDA	MDA
strontium-90	Ci	MDA	MDA
zinc-65	Ci	MDA	MDA
zirconium-95	Ci	MDA	MDA
TOTAL FOR PERIOD	Ci	5.04E-4	2.65E-4

MDA = Less than the "a posteriori" minimum detectable activity (microcuries per unit mass or volume).
This note applies to all tables.

**DIABLO CANYON POWER PLANT
ANNUAL RADIOACTIVE EFFLUENT RELEASE REPORT 2002**

**TABLE 2B
GASEOUS EFFLUENTS - GROUND LEVEL RELEASES**

Nuclides Released	Units	Third Quarter		Fourth Quarter	
		Continuous Mode	Batch Mode	Continuous Mode	Batch Mode

1. Fission gases

argon-41	Ci	MDA	2.22E-2	8.73E-1	1.84E-2
krypton-85	Ci	MDA	5.53E-2	MDA	2.76E-1
krypton-85m	Ci	MDA	MDA	MDA	MDA
krypton-87	Ci	MDA	MDA	MDA	MDA
krypton-88	Ci	MDA	MDA	MDA	MDA
xenon-131m	Ci	MDA	1.12E-2	MDA	1.04E-2
xenon-133	Ci	MDA	3.98E-1	MDA	2.51E+0
xenon-133m	Ci	MDA	1.14E-3	MDA	1.91E-4
xenon-135	Ci	2.71E-1	1.04E-4	5.39E-5	3.21E-2
xenon-135m	Ci	MDA	MDA	MDA	MDA
xenon-138	Ci	MDA	MDA	MDA	MDA
TOTAL FOR PERIOD	Ci	2.71E-1	4.88E-1	8.74E-1	2.84E+0

2. Iodines

iodine-131	Ci	1.95E-5
iodine-133	Ci	3.55E-5
iodine-135	Ci	MDA
TOTAL FOR PERIOD	Ci	5.50E-5

2.02E-3
1.06E-4
MDA
2.12E-3

MDA = Less than the "a posteriori" minimum detectable activity (microcuries per unit mass or volume). This note applies to all tables.

**DIABLO CANYON POWER PLANT
ANNUAL RADIOACTIVE EFFLUENT RELEASE REPORT 2002
TABLE 2B (Continued)
GASEOUS EFFLUENTS - GROUND LEVEL RELEASES**

Nuclides Released	Units	Continuous Mode	
		Third Quarter	Fourth Quarter

3. Particulates

barium-140	Ci	MDA	MDA
cesium-134	Ci	MDA	MDA
cesium-137	Ci	MDA	1.25E-4
cerium-141	Ci	MDA	MDA
cerium-144	Ci	MDA	MDA
chromium-51	Ci	MDA	MDA
cobalt-57	Ci	MDA	MDA
cobalt-58	Ci	2.35E-5	MDA
cobalt-60	Ci	MDA	MDA
iron-59	Ci	MDA	MDA
lanthanum-140	Ci	MDA	MDA
manganese-54	Ci	MDA	MDA
molybdenum-99	Ci	MDA	MDA
ruthenium-103	Ci	MDA	MDA
strontium-89	Ci	MDA	MDA
strontium-90	Ci	MDA	MDA
zinc-65	Ci	MDA	MDA
zirconium-95	Ci	MDA	MDA
TOTAL FOR PERIOD	Ci	2.35E-5	1.25E-4

MDA = Less than the "a posteriori" minimum detectable activity (microcuries per unit mass or volume).
This note applies to all tables.

DIABLO CANYON POWER PLANT
ANNUAL RADIOACTIVE EFFLUENT RELEASE REPORT 2002

TABLE 3
GASEOUS EFFLUENTS - LOWER LIMITS OF DETECTION

Nuclide	Units	Continuous Mode	Batch Mode	
			Containment Purge	Gas Decay Tank

1. Fission gases

argon-41	μCi/ml	1.52E-8	1.52E-8	1.52E-8
krypton-85	μCi/ml	2.37E-6	2.37E-6	2.37E-6
krypton-85m	μCi/ml	8.22E-9	8.22E-9	8.22E-9
krypton-87	μCi/ml	2.90E-8	2.90E-8	2.90E-8
krypton-88	μCi/ml	2.88E-8	2.88E-8	2.88E-8
xenon-131m	μCi/ml	2.79E-7	2.79E-7	2.79E-7
xenon-133	μCi/ml	1.99E-8	1.99E-8	1.99E-8
xenon-133m	μCi/ml	5.77E-8	5.77E-8	5.77E-8
xenon-135	μCi/ml	6.84E-9	6.84E-9	6.84E-9
xenon-135m	μCi/ml	2.54E-7	2.54E-7	2.54E-7
xenon-138	μCi/ml	7.37E-7	7.37E-7	7.37E-7

2. Tritium

hydrogen-3	μCi/ml	4.18E-9	4.18E-9	N/A
------------	--------	---------	---------	-----

3. Iodines

iodine-131	μCi/ml	4.87E-13	N/A
iodine-133	μCi/ml	7.36E-13	N/A
iodine-135	μCi/ml	3.26E-12	N/A

**DIABLO CANYON POWER PLANT
 ANNUAL RADIOACTIVE EFFLUENT RELEASE REPORT 2002
 TABLE 3 (Continued)
 GASEOUS EFFLUENTS - LOWER LIMITS OF DETECTION**

Nuclide	Units	Continuous Mode
---------	-------	-----------------

4. Particulates

barium-140	μCi/ml	1.96E-12
cesium-134	μCi/ml	3.80E-13
cesium-137	μCi/ml	6.63E-13
cerium-141	μCi/ml	5.17E-13
cerium-144	μCi/ml	2.15E-12
chromium-51	μCi/ml	2.76E-12
cobalt-57	μCi/ml	2.44E-13
cobalt-58	μCi/ml	5.09E-13
cobalt-60	μCi/ml	6.74E-13
iron-59	μCi/ml	1.26E-12
lanthanum-140	μCi/ml	6.38E-13
manganese-54	μCi/ml	4.31E-13
molybdenum-99	μCi/ml	2.34E-13
ruthenium-103	μCi/ml	4.11E-13
strontium-89	μCi/ml	2.10E-14
strontium-90	μCi/ml	6.52E-15
zinc-65	μCi/ml	1.22E-12
zirconium-95	μCi/ml	7.32E-13
gross alpha	μCi/ml	2.35E-15

DIABLO CANYON POWER PLANT
ANNUAL RADIOACTIVE EFFLUENT RELEASE REPORT 2002

TABLE 4A
LIQUID EFFLUENTS - SUMMATION OF ALL RELEASES

Units	First Quarter	Second Quarter	Est Total Error %
-------	---------------	----------------	-------------------

A. Fission and activation products

1. Total release (not including tritium, gases, alpha)	Ci	2.26E-2	3.82E-2	24%
2. Average diluted concentration during period	μCi/ml	8.29E-12	1.73E-11	
3. Percent of applicable limit ¹	%	1.67E-4	2.73E-4	

B. Tritium

1. Total release	Ci	1.84E+2	4.11E+2	13%
2. Average diluted concentration during period	μCi/ml	6.75E-8	1.86E-7	
3. Percent of applicable limit ¹	%	6.75E-3	1.86E-2	

C. Dissolved and entrained gasses

1. Total release	Ci	MDA	3.79E-4	24%
2. Average diluted concentration during period	μCi/ml	MDA	1.71E-13	
3. Percent of applicable limit ¹	%	MDA	8.56E-8	

D. Gross Alpha

1. Total release	Ci	MDA	2.36E-5	61%
------------------	----	-----	---------	-----

E.

Volume of waste release (prior to dilution)	liters	9.27E+7	8.53E+7	5%
---	--------	---------	---------	----

F.

Volume of circulating saltwater used during release periods	liters	2.72E+12	2.21E+12	7%
---	--------	----------	----------	----

MDA = Less than the "a posteriori" minimum detectable activity (microcuries per unit mass or volume). This note applies to all tables.

¹ RECP 6 1.3.1 Limit

**DIABLO CANYON POWER PLANT
ANNUAL RADIOACTIVE EFFLUENT RELEASE REPORT 2002**

**TABLE 4B
LIQUID EFFLUENTS - SUMMATION OF ALL RELEASES**

Units	Third Quarter	Fourth Quarter	Est.Total Error %
-------	---------------	----------------	-------------------

A. Fission and activation products

1. Total release (not including tritium, gases, alpha)	Ci	2.98E-2	4.17E-2	24%
2. Average diluted concentration during period	μCi/ml	1.12E-11	2.00E-11	
3. Percent of applicable limit ¹	%	2.18E-4	8.03E-4	

B. Tritium

1. Total release	Ci	2.29E+2	5.50E+2	13%
2. Average diluted concentration during period	μCi/ml	8.59E-8	2.64E-7	
3. Percent of applicable limit ¹	%	8.59E-3	2.64E-2	

C. Dissolved and entrained gasses

1. Total release	Ci	2.34E-3	9.83E-3	24%
2. Average diluted concentration during period	μCi/ml	8.80E-13	4.72E-12	
3. Percent of applicable limit ¹	%	4.40E-7	2.36E-6	

D. Gross Alpha

1. Total release	Ci	MDA	MDA	61%
------------------	----	-----	-----	-----

E.

Volume of waste release (prior to dilution)	liters	8.40E+7	8.05E+7	5%
---	--------	---------	---------	----

F.

Volume of circulating saltwater used during release periods	liters	2.66E+12	2.08E+12	7%
---	--------	----------	----------	----

MDA = Less than the "a posteriori" minimum detectable activity (microcuries per unit mass or volume). This note applies to all tables.

¹ RECP 6.1.3.1 Limit

DIABLO CANYON POWER PLANT
 ANNUAL RADIOACTIVE EFFLUENT RELEASE REPORT 2002

TABLE 4C
 LIQUID EFFLUENTS - SUMMATION OF ALL RELEASES

	Units	Annual Total
--	-------	--------------

A. Fission and activation products

1. Total release (not including tritium, gases, alpha)	Ci	1.32E-1
2. Average diluted concentration during period	μCi/ml	1.37E-11
3. Percent of applicable limit ¹	%	3.42E-4

B. Tritium

1. Total release	Ci	1.37E+3
2. Average diluted concentration during period	μCi/ml	1.42E-7
3. Percent of applicable limit ¹	%	1.42E-2

C. Dissolved and entrained gasses

1. Total release	Ci	1.26E-2
2. Average diluted concentration during period	μCi/ml	1.30E-12
3. Percent of applicable limit ¹	%	6.49E-7

D. Gross Alpha

1. Total release	Ci	2.36E-5
------------------	----	---------

E. Volume of waste release (prior to dilution)	liters	3.43E+8
--	--------	---------

F. Volume of circulating saltwater used during release periods	liters	9.68E+12
--	--------	----------

MDA = Less than the "a posteriori" minimum detectable activity (microcuries per unit mass or volume).
 This note applies to all tables.

¹ RECP 6.1.3.1 Limit

DIABLO CANYON POWER PLANT
ANNUAL RADIOACTIVE EFFLUENT RELEASE REPORT 2002

TABLE 5A
LIQUID EFFLUENTS - NUCLIDES RELEASED

Nuclides Released	Units	First Quarter		Second Quarter	
		Continuous Mode	Batch Mode	Continuous Mode	Batch Mode
antimony-122	Ci	MDA	MDA	MDA	3.28E-5
antimony-124	Ci	MDA	MDA	MDA	1.91E-4
antimony-125	Ci	MDA	1.30E-3	MDA	5.24E-3
barium-140	Ci	MDA	MDA	MDA	MDA
beryllium-7	Ci	MDA	MDA	MDA	MDA
bromine-82	Ci	MDA	MDA	MDA	MDA
cerium-141	Ci	MDA	MDA	MDA	MDA
cerium-143	Ci	MDA	MDA	MDA	MDA
cerium-144	Ci	MDA	MDA	MDA	MDA
cesium-134	Ci	MDA	1.50E-4	MDA	4.95E-4
cesium-136	Ci	MDA	MDA	MDA	MDA
cesium-137	Ci	2.21E-4	4.78E-4	MDA	1.25E-3
cesium-138	Ci	MDA	MDA	MDA	MDA
chromium-51	Ci	MDA	MDA	MDA	1.39E-3
cobalt-57	Ci	MDA	6.34E-5	MDA	1.15E-4
cobalt-58	Ci	MDA	3.25E-3	1.29E-4	1.03E-2
cobalt-60	Ci	MDA	5.88E-3	MDA	8.24E-3
iron-55	Ci	MDA	8.20E-3	MDA	7.51E-3
iron-59	Ci	MDA	MDA	MDA	4.98E-5
lanthanum-140	Ci	MDA	MDA	MDA	MDA

MDA = Less than the "a posteriori" minimum detectable activity (microcuries per unit mass or volume). This note applies to all tables

**DIABLO CANYON POWER PLANT
ANNUAL RADIOACTIVE EFFLUENT RELEASE REPORT 2002
TABLE 5A (CONTINUED)
LIQUID EFFLUENTS - NUCLIDES RELEASED**

Nuclides Released	Units	First Quarter		Second Quarter	
		Continuous Mode	Batch Mode	Continuous Mode	Batch Mode
lanthanum-142	Ci	MDA	MDA	MDA	MDA
manganese-54	Ci	MDA	2.24E-4	MDA	3.24E-4
manganese-56	Ci	MDA	MDA	MDA	MDA
molybdenum-99	Ci	MDA	1.03E-5	MDA	1.97E-5
niobium-95	Ci	MDA	MDA	MDA	8.53E-5
neodymium-147	Ci	MDA	MDA	MDA	MDA
rubidium-89	Ci	MDA	MDA	MDA	MDA
ruthenium-103	Ci	MDA	MDA	MDA	MDA
silver-110m	Ci	MDA	9.11E-6	MDA	9.64E-5
sodium-24	Ci	MDA	MDA	MDA	MDA
strontium-89	Ci	MDA	MDA	MDA	MDA
strontium-90	Ci	MDA	5.81E-5	MDA	MDA
strontium-91	Ci	MDA	MDA	MDA	MDA
strontium-92	Ci	MDA	1.00E-5	MDA	8.51E-6
tellurium-129m	Ci	MDA	MDA	MDA	MDA
tellurium-131	Ci	MDA	MDA	MDA	MDA
tellurium-132	Ci	MDA	MDA	MDA	MDA
tin-113	Ci	MDA	MDA	MDA	MDA

MDA = Less than the "a posteriori" minimum detectable activity (microcuries per unit mass or volume). This note applies to all tables.

**DIABLO CANYON POWER PLANT
ANNUAL RADIOACTIVE EFFLUENT RELEASE REPORT 2002
TABLE 5A (CONTINUED)
LIQUID EFFLUENTS - NUCLIDES RELEASED**

Nuclides Released	Units	First Quarter		Second Quarter	
		Continuous Mode	Batch Mode	Continuous Mode	Batch Mode
tin-117m	Ci	MDA	MDA	MDA	MDA
tungsten-187	Ci	MDA	MDA	MDA	MDA
zinc-65	Ci	MDA	1.72E-3	MDA	2.64E-3
zirconium-95	Ci	MDA	MDA	MDA	MDA
iodine-131	Ci	5.01E-4	4.65E-4	MDA	1.27E-4
iodine-132	Ci	MDA	MDA	MDA	MDA
iodine-133	Ci	MDA	1.67E-5	MDA	5.88E-6
iodine-134	Ci	MDA	MDA	MDA	MDA
iodine-135	Ci	MDA	MDA	MDA	MDA
TOTAL FOR PERIOD	Ci	7.22E-4	2.18E-2	1.29E-4	3.81E-2

DISSOLVED AND ENTRAINED GASES

xenon-133	Ci	MDA	MDA	MDA	3.79E-4
xenon-133m	Ci	MDA	MDA	MDA	MDA
xenon-135	Ci	MDA	MDA	MDA	MDA
krypton-85	Ci	MDA	MDA	MDA	MDA
krypton-87	Ci	MDA	MDA	MDA	MDA
krypton-88	Ci	MDA	MDA	MDA	MDA
TOTAL FOR PERIOD	Ci	MDA	MDA	MDA	3.79E-4

MDA = Less than the "a posteriori" minimum detectable activity (microcuries per unit mass or volume) This note applies to all tables.

DIABLO CANYON POWER PLANT
ANNUAL RADIOACTIVE EFFLUENT RELEASE REPORT 2002

TABLE 5B
LIQUID EFFLUENTS - NUCLIDES RELEASED

Nuclides Released	Units	Third Quarter		Fourth Quarter	
		Continuous Mode	Batch Mode	Continuous Mode	Batch Mode
antimony-122	Ci	MDA	MDA	MDA	MDA
antimony-124	Ci	MDA	MDA	MDA	MDA
antimony-125	Ci	MDA	1.59E-3	MDA	2.02E-3
barium-140	Ci	MDA	MDA	MDA	MDA
beryllium-7	Ci	MDA	MDA	MDA	MDA
bromine-82	Ci	MDA	MDA	MDA	MDA
cerium-141	Ci	MDA	MDA	MDA	MDA
cerium-143	Ci	MDA	MDA	MDA	MDA
cerium-144	Ci	MDA	MDA	MDA	MDA
cesium-134	Ci	MDA	5.96E-4	1.31E-3	7.71E-4
cesium-136	Ci	MDA	MDA	MDA	7.04E-7
cesium-137	Ci	MDA	1.38E-3	1.98E-3	1.56E-3
cesium-138	Ci	MDA	MDA	MDA	MDA
chromium-51	Ci	MDA	2.61E-4	MDA	3.55E-5
cobalt-57	Ci	MDA	5.67E-5	MDA	1.07E-4
cobalt-58	Ci	MDA	1.00E-2	MDA	8.94E-3
cobalt-60	Ci	MDA	5.33E-3	MDA	6.56E-3
iron-55	Ci	MDA	6.17E-3	MDA	7.97E-3
iron-59	Ci	MDA	MDA	MDA	MDA
lanthanum-140	Ci	MDA	MDA	MDA	MDA

MDA = Less than the "a posteriori" minimum detectable activity (microcuries per unit mass or volume). This note applies to all tables.

**DIABLO CANYON POWER PLANT
ANNUAL RADIOACTIVE EFFLUENT RELEASE REPORT 2002
TABLE 5B (CONTINUED)
LIQUID EFFLUENTS - NUCLIDES RELEASED**

Nuclides Released	Units	Third Quarter		Fourth Quarter	
		Continuous Mode	Batch Mode	Continuous Mode	Batch Mode
lanthanum-142	Ci	MDA	MDA	MDA	MDA
manganese-54	Ci	MDA	2.64E-4	MDA	1.64E-4
manganese-56	Ci	MDA	MDA	MDA	MDA
molybdenum-99	Ci	MDA	4.96E-5	MDA	2.08E-4
niobium-95	Ci	MDA	3.63E-4	MDA	4.15E-5
neodymium-147	Ci	MDA	MDA	MDA	MDA
rubidium-89	Ci	MDA	MDA	MDA	MDA
ruthenium-103	Ci	MDA	MDA	MDA	MDA
silver-110m	Ci	MDA	5.73E-5	MDA	1.02E-4
sodium-24	Ci	MDA	MDA	MDA	MDA
strontium-89	Ci	MDA	MDA	MDA	MDA
strontium-90	Ci	MDA	MDA	MDA	MDA
strontium-91	Ci	MDA	MDA	MDA	MDA
strontium-92	Ci	MDA	5.09E-6	MDA	4.53E-6
tellurium-129m	Ci	MDA	MDA	MDA	MDA
tellurium-131	Ci	MDA	MDA	MDA	MDA
tellurium-132	Ci	MDA	MDA	MDA	MDA
tin-113	Ci	MDA	4.50E-6	MDA	MDA

MDA = Less than the "a posteriori" minimum detectable activity (microcuries per unit mass or volume). This note applies to all tables.

**DIABLO CANYON POWER PLANT
ANNUAL RADIOACTIVE EFFLUENT RELEASE REPORT 2002
TABLE 5B (CONTINUED)
LIQUID EFFLUENTS - NUCLIDES RELEASED**

Nuclides Released	Units	Third Quarter		Fourth Quarter	
		Continuous Mode	Batch Mode	Continuous Mode	Batch Mode
tin-117m	Ci	MDA	MDA	MDA	MDA
tungsten-187	Ci	MDA	MDA	MDA	MDA
zinc-65	Ci	MDA	2.47E-3	MDA	1.79E-3
zirconium-95	Ci	MDA	1.26E-4	MDA	MDA
iodine-131	Ci	8.88E-5	7.12E-4	3.85E-3	3.76E-3
iodine-132	Ci	MDA	MDA	MDA	9.89E-7
iodine-133	Ci	1.61E-4	3.63E-5	7.26E-5	4.49E-4
iodine-134	Ci	MDA	MDA	MDA	MDA
iodine-135	Ci	MDA	MDA	MDA	5.43E-6
TOTAL FOR PERIOD	Ci	2.50E-4	2.95E-2	7.22E-3	3.45E-2

DISSOLVED AND ENTRAINED GASES

xenon-133	Ci	MDA	2.34E-3	MDA	9.78E-3
xenon-133m	Ci	MDA	MDA	MDA	MDA
xenon-135	Ci	MDA	MDA	3.63E-5	2.09E-5
krypton-85	Ci	MDA	MDA	MDA	MDA
krypton-87	Ci	MDA	MDA	MDA	MDA
krypton-88	Ci	MDA	MDA	MDA	MDA
TOTAL FOR PERIOD	Ci	MDA	2.34E-3	3.63E-5	9.80E-3

MDA = Less than the "a posteriori" minimum detectable activity (microcuries per unit mass or volume). This note applies to all tables.

DIABLO CANYON POWER PLANT
 ANNUAL RADIOACTIVE EFFLUENT RELEASE REPORT 2002

TABLE 6
 LIQUID EFFLUENTS - LOWER LIMITS OF DETECTION

Nuclide	Units	LLD
antimony-122	μCi/ml	1.14E-7
antimony-124	μCi/ml	6.70E-8
antimony-125	μCi/ml	2.72E-7
barium-140	μCi/ml	3.20E-7
beryllium-7	μCi/ml	7.75E-7
bromine-82	μCi/ml	1.18E-7
cerium-141	μCi/ml	1.04E-7
cerium-143	μCi/ml	1.72E-7
cerium-144	μCi/ml	4.49E-7
cesium-134	μCi/ml	6.74E-8
cesium-136	μCi/ml	8.70E-8
cesium-137	μCi/ml	1.54E-7
cesium-138	μCi/ml	7.85E-7
chromium-51	μCi/ml	6.48E-7
cobalt-57	μCi/ml	5.19E-8
cobalt-58	μCi/ml	1.48E-7
cobalt-60	μCi/ml	1.21E-7
iron-55	μCi/ml	3.00E-7
iron-59	μCi/ml	2.02E-7
lanthanum-140	μCi/ml	1.98E-7
lanthanum-142	μCi/ml	3.75E-7
manganese-54	μCi/ml	1.16E-7
manganese-56	μCi/ml	4.33E-7
molybdenum-99	μCi/ml	6.43E-8
niobium-95	μCi/ml	1.08E-7

**DIABLO CANYON POWER PLANT
ANNUAL RADIOACTIVE EFFLUENT RELEASE REPORT 2002
TABLE 6 (CONTINUED)
LIQUID EFFLUENTS - LOWER LIMITS OF DETECTION**

Nuclide	Units	LLD
neodymium-147	μCi/ml	2.83E-7
rubidium-89	μCi/ml	5.58E-6
ruthenium-103	μCi/ml	1.01E-7
silver-110m	μCi/ml	8.70E-8
sodium-24	μCi/ml	1.54E-7
strontium-89	μCi/ml	4.95E-8
strontium-90	μCi/ml	1.78E-8
strontium-91	μCi/ml	1.45E-7
strontium-92	μCi/ml	2.56E-7
tellurium-129m	μCi/ml	3.35E-6
tellurium-131	μCi/ml	4.58E-7
tellurium-132	μCi/ml	5.90E-8
tin-113	μCi/ml	1.09E-7
tin-117m	μCi/ml	5.55E-8
tungsten-187	μCi/ml	3.40E-7
zinc-65	μCi/ml	2.51E-7
zirconium-95	μCi/ml	1.38E-7
gross alpha	μCi/ml	9.12E-8
hydrogen-3	μCi/ml	3.97E-6

**DIABLO CANYON POWER PLANT
 ANNUAL RADIOACTIVE EFFLUENT RELEASE REPORT 2002
 TABLE 6 (CONTINUED)
 LIQUID EFFLUENTS - LOWER LIMITS OF DETECTION**

Nuclide	Units	LLD
iodine-131	μCi/ml	8.13E-8
iodine-132	μCi/ml	1.27E-7
iodine-133	μCi/ml	1.18E-7
iodine-134	μCi/ml	2.76E-7
iodine-135	μCi/ml	5.90E-7
xenon-133	μCi/ml	7.54E-8
xenon-133m	μCi/ml	2.01E-7
xenon-135	μCi/ml	2.40E-8
krypton-85	μCi/ml	1.18E-5
krypton-87	μCi/ml	1.01E-7
krypton-88	μCi/ml	8.92E-8

IX. Solid Radwaste Shipments

IX. Solid Radwaste Shipments

Solid Waste and Irradiated Fuel Shipment

A. Solid Waste Shipped Off-site for Burial or Disposal (Not irradiated fuel)

1. Type of Waste	Unit	12 Month Period	Est. Total Error, %
a. Spent Resins, Filter Sludges, Evaporator Bottoms, etc.	m ³ Ci	1.01E+01 3.23E+2	8.99E+0
b. Dry Compressible Waste, Contaminated Equipment, etc.	m ³ Ci	7.58E+0 1.27E+0	9.00E+0
c. Irradiated Components, Control Rods, etc.	m ³ Ci	0.00E+0 0.00E+0	0.00E+0
d. Other	m ³ Ci	0.00E+0 0.00E+0	0.00E+0

2. Estimate of Major Nuclide Composition (by type of waste)

a.	Co-60	%	3.50E+01
	Ni-63	%	1.60E+01
	Fe-55	%	1.30E+01
	Co-58	%	8.2E+00
	Nb-95	%	4.6E+00

b.	Fe-55	%	3.02E+01
	Co-60	%	1.84E+01
	Co-58	%	1.49E+01
	Mn-54	%	1.42E+01
	H-3	%	8.24E+00
	Ni-63	%	3.75E+00
	Nb-95	%	2.47E+00
	C-14	%	1.67E+00
	Zr-95	%	1.58E+00

c.	Not Applicable	%	N/A
----	----------------	---	-----

d.	Not Applicable	%	N/A
----	----------------	---	-----

Solid Waste and Irradiated Fuel Shipment (Continued)

3. Solid Waste Disposition

Number of Shipments	Mode of Transportation	Destination
3	Truck	BARNWELL, SC
19	Truck	CLIVE, UT

4. Supplemental Information Required by former TS 6.9.1.6

Solidification Agent	Type of Container	Number of Containers	10 CFR 61 Waste Class	Shipping Type
Cement	Strong, Tight	1	C	Type A
Polymer	Strong, Tight	1	B	Type B
None	Type A, HIC	1	C	Type B
None	Strong, Tight	21	AU	LSA

B. Irradiated Fuel Shipments (Disposition)

Number of Shipments	Mode of Transportation	Destination
None	N/A	N/A

X. Radiation Dose Due to Gaseous and Liquid Effluents

Radiation Doses

A. Radiation doses from radioactive liquid effluents

The radiation dose contributions due to releases of radioactive liquid effluents to the total body and each individual organ for the maximum exposed adult have been calculated in accordance with the methodology in the ODCP. Dose contributions listed in Table 7 show conformance to RECP 6.1.4.1.

B. Radiation doses from radioactive gaseous effluents

The radiation dose contributions due to radioactive gaseous effluents at the site boundary for the land sectors have been calculated in accordance with the calculation methodology in the ODCP. Each unit's dose contribution has been calculated separately. The latest five-year historical average meteorology conditions were used in these calculations. In addition to the site boundary doses, the dose to an individual (critical receptor) due to radioiodines, tritium, and particulates released in gaseous effluents with half-lives greater than eight days is determined in accordance with the methodology in the ODCP based on the methodology described in NUREG-0133. Dose contributions listed in Table 8, which represents the maximum dose for age groups, organs, and geographic locations for the report period, show conformance to RECP 6.1.6.1, 6.1.7.1, and 6.1.8.1.

C. Radiation Doses from Direct Radiation (Line-of-Sight Plus Sky-Shine) - Closest Site Boundary (800 m)

For the report period, the radiation dose is evaluated to be $6.58E-3$ mR due to the presence of radioactive waste containers outside of plant buildings and the storage of contaminated tools and equipment inside plant buildings.

D. Radiation Doses from Chemistry Laboratory Radioactive Gaseous Effluents - Closest Site Boundary (800m)

The radiation dose due to chemistry laboratory radioactive gaseous effluents for the report period is evaluated to be $9.90E-6$ mR.

E. Radiation Doses from Post accident Sampling System Radioactive Gaseous Effluents - Closest Site Boundary (800m)

The radiation doses due to post accident sampling system radioactive gaseous effluents for the report period is evaluated to be $7.59E-6$ mR.

F. 40 CFR 190 Considerations

The release of radioactivity in liquid and gaseous effluents resulted in doses that are small percentages of the TS limits as shown in Tables 9 and 10. This, coupled with the fact that there are no other uranium fuel cycle sources within eight kilometers of the DCP, shows conformance to 40 CFR 190.

G. Radiation Doses from Radioactive Liquid And Gaseous Effluents to Members of the Public Due To Their Activities Inside The Site Boundary

1. Liquid Effluents

The radiation dose to members of the public within the site boundary due to the release of radioactive liquid effluents is negligible because the discharge piping for liquid radwaste is mostly imbedded in concrete, located in remote or inaccessible areas, or is underground. In addition, the quantity of radioactivity released was very low.

2. Gaseous Effluents

The radiation dose to members of the public within the site boundary due to the release of radioactive gaseous effluents are listed in Table 11.

**DIABLO CANYON POWER PLANT
 ANNUAL RADIOACTIVE EFFLUENT RELEASE REPORT 2002**

**TABLE 7
 RADIATION DOSE DUE TO THE RELEASE OF RADIOACTIVE LIQUID EFFLUENTS**

	millirem				
	First Quarter	Second Quarter	Third Quarter	Fourth Quarter	Annual Total
Total Body	2.74E-04	5.05E-04	3.64E-04	4.84E-04	1.63E-03
Bone	3.70E-04	5.33E-04	3.72E-04	5.38E-04	1.81E-03
Liver	6.33E-04	1.09E-03	7.98E-04	1.00E-03	3.52E-03
Thyroid	6.68E-05	5.35E-05	5.85E-05	7.07E-04	8.85E-04
Kidney	3.21E-04	6.03E-04	4.55E-04	5.29E-04	1.91E-03
Lung	1.00E-04	1.52E-04	8.25E-05	1.85E-04	5.19E-04
G.I. LLI	5.13E-04	1.08E-03	9.34E-04	8.90E-04	3.42E-03

DIABLO CANYON POWER PLANT
 ANNUAL RADIOACTIVE EFFLUENT RELEASE REPORT 2002

TABLE 8A

RADIATION DOSE¹ DUE TO THE RELEASE OF RADIOACTIVE GASEOUS EFFLUENTS (UNIT 1)

Site Boundary	First Quarter Dose	Second Quarter Dose	Third Quarter Dose	Fourth Quarter Dose	Annual Total Dose
Noble Gas					
Gamma Air Dose	4.27E-3	1.81E-3	2.03E-5	1.05E-3	7.16E-3
Beta Air Dose	1.74E-3	7.36E-4	7.14E-6	7.75E-4	3.26E-3

Nearest Residence-NNW	First Quarter Dose	Second Quarter Dose	Third Quarter Dose	Fourth Quarter Dose	Annual Total Dose
I, P, T ^{2,3}					
Critical Receptor (Highest Organ)	2.83E-4	1.69E-3	6.26E-4	1.59E-3	4.19E-3

Nearest Vegetable Garden - ESE	First Quarter Dose	Second Quarter Dose	Third Quarter Dose	Fourth Quarter Dose	Annual Total Dose
I, P, T ^{2,4}					
Critical Receptor (Highest Organ)	1.59E-4	1.02E-3	3.51E-4	8.94E-4	2.42E-3

DIABLO CANYON POWER PLANT
 ANNUAL RADIOACTIVE EFFLUENT RELEASE REPORT 2002
 TABLE 8B

RADIATION DOSE¹ DUE TO THE RELEASE OF RADIOACTIVE GASEOUS EFFLUENTS (UNIT 2)

Site Boundary	First Quarter Dose	Second Quarter Dose	Third Quarter Dose	Fourth Quarter Dose	Annual Total Dose
Noble Gas					
Gamma Air Dose	4.18E-4	2.46E-5	1.31E-4	5.61E-4	1.14E-3
Beta Air Dose	1.28E-3	1.74E-5	2.16E-4	3.04E-4	1.82E-3

Nearest Residence-NNW	First Quarter Dose	Second Quarter Dose	Third Quarter Dose	Fourth Quarter Dose	Annual Total Dose
I, P, T ^{2,3}					
Critical Receptor (Highest Organ)	5.04E-4	2.89E-4	2.65E-4	1.09E-3	2.15E-3

Nearest Vegetable Garden - ESE	First Quarter Dose	Second Quarter Dose	Third Quarter Dose	Fourth Quarter Dose	Annual Total Dose
I, P, T ^{2,4}					
Critical Receptor (Highest Organ)	4.48E-4	1.63E-4	1.67E-4	2.55E-3	3.33E-3

Notes for Tables 8a and 8b

1. This represents the maximum dose of age groups, organs, and geographic locations for the quarter and the year.
2. Radioiodines, radioactive material in particulate form, and radionuclides other than noble gases with half-lives greater than eight days.
3. The inhalation and ground plane pathways are included for this location.
4. The inhalation, ground plane and vegetable pathways are included for this location. An occupancy factor of 0.5 was used for the inhalation and ground plane pathways. The teen age group had the highest calculated dose for this location.

DIABLO CANYON POWER PLANT
 ANNUAL RADIOACTIVE EFFLUENT RELEASE REPORT 2002
 TABLE 9

PERCENT OF TECHNICAL SPECIFICATION LIMITS¹ FOR RADIOACTIVE LIQUID EFFLUENTS

	Percent				
	First Quarter	Second Quarter	Third Quarter	Fourth Quarter	Annual Total
Total Body	1.83E-02	3.37E-02	2.42E-02	3.22E-02	5.42E-02
Bone	7.39E-03	1.07E-02	7.44E-03	1.08E-02	1.81E-02
Liver	1.27E-02	2.18E-02	1.60E-02	2.01E-02	3.52E-02
Thyroid	1.34E-03	1.07E-03	1.17E-03	1.41E-02	8.85E-03
Kidney	6.43E-03	1.21E-02	9.11E-03	1.06E-02	1.91E-02
Lung	2.01E-03	3.04E-03	1.65E-03	3.70E-03	5.19E-03
G.I. LLI	1.03E-02	2.16E-02	1.87E-02	1.78E-02	3.42E-02

NOTE:

¹RECP 6.1.4.1

DIABLO CANYON POWER PLANT
ANNUAL RADIOACTIVE EFFLUENT RELEASE REPORT 2002
TABLE 10A

PERCENT OF TECHNICAL SPECIFICATION LIMITS¹ FOR RADIOACTIVE GASEOUS EFFLUENTS (UNIT 1)

Site Boundary		First Quarter % of TS Limit	Second Quarter % of TS Limit	Third Quarter % of TS Limit	Fourth Quarter % of TS Limit	Annual Total % of TS Limit
Noble Gas						
	Gamma Air Dose	8.55E-2	3.63E-2	4.05E-4	2.10E-2	7.16E-2
	Beta Air Dose	1.74E-2	7.36E-3	7.14E-5	7.75E-3	1.63E-2
Nearest Residence - NNW						
I.P.T. Critical Receptor (Highest Organ)		3.78E-3	2.25E-2	8.34E-3	2.12E-2	2.79E-2
Nearest Vegetable Garden - ESE						
I.P.T. Critical Receptor (Highest Organ)		2.12E-3	1.36E-2	4.68E-3	1.19E-2	1.61E-2

NOTE:

¹RECP 6.1.6.1, 6.1.7.1 and 6.1.8.1

DIABLO CANYON POWER PLANT
ANNUAL RADIOACTIVE EFFLUENT RELEASE REPORT 2002
TABLE 10B

PERCENT OF TECHNICAL SPECIFICATION LIMITS¹ FOR RADIOACTIVE GASEOUS EFFLUENTS (UNIT 2)

Site Boundary	First Quarter % of TS Limit	Second Quarter % of TS Limit	Third Quarter % of TS Limit	Fourth Quarter % of TS Limit	Annual Total % of TS Limit
Noble Gas					
Gamma Air Dose	8.37E-3	4.91E-4	2.63E-3	1.12E-2	1.14E-2
Beta Air Dose	1.28E-2	1.74E-4	2.16E-3	3.04E-3	9.09E-3
Nearest Residence-NNW					
I.P.T.					
Critical Receptor (Highest Organ)	6.72E-3	3.86E-3	3.53E-3	1.45E-2	1.43E-2
Nearest Vegetable Garden - ESE					
I.P.T. (ESE)					
Critical Receptor (Highest Organ)	5.98E-3	2.17E-3	2.23E-3	3.40E-2	2.22E-2

NOTE:

¹RECP 6.1.6.1, 6.1.7.1 and 6.1.8.1

**DIABLO CANYON POWER PLANT
ANNUAL RADIOACTIVE EFFLUENT RELEASE REPORT 2002
TABLE 11A
RADIATION DOSE DUE TO RELEASE OF RADIOACTIVE GASEOUS EFFLUENTS
FIRST QUARTER, 2002
ON-SITE DOSE TO MEMBERS OF THE PUBLIC (SPECIAL INTEREST GROUPS)**

Specific Activity	Exposure Location (Sectors)	Exposure Closest Dist. (meters)	Exposure Time (Hours)	External Dose				Internal Dose
				Noble Gas			Iodines, Particulates, and Tritium	
				Whole Body	Skin	Ground Plane		
Police at Shooting Range	SE	700	52.0	1.62E-4	2.51E-4	1.90E-4	1.48E-4	
Tour Participants								
(a) Simulator Bldg.	S	310	1.00	2.12E-6	3.30E-6	1.32E-6	1.94E-6	
(b) Bio Lab	SSE	460	1.50	3.18E-6	4.94E-6	3.00E-6	2.90E-6	
(c) Overlook	E	210	0.25	1.48E-6	2.29E-6	4.31E-7	1.35E-6	
American Indians	NW	200	24.0	5.86E-4	9.10E-4	1.97E-4	5.35E-4	
at Burial Grounds	NNW	200	24.0	4.10E-4	6.37E-4	1.12E-4	3.74E-4	
Ranch Hands driving cattle around site								
	NW	250	0.25	4.09E-6	6.35E-6	1.44E-6	3.73E-6	
	NNW	350	0.25	1.57E-6	2.43E-6	4.87E-7	1.43E-6	
	N	320	0.25	1.04E-6	1.62E-6	2.45E-7	9.49E-7	
	NNE	450	0.25	4.07E-7	6.32E-7	1.06E-7	3.71E-7	
	NE	630	0.25	2.07E-7	3.21E-7	6.49E-8	1.89E-7	

NOTE: All doses are in mrem.

**DIABLO CANYON POWER PLANT
ANNUAL RADIOACTIVE EFFLUENT RELEASE REPORT 2002
TABLE 11B
RADIATION DOSE DUE TO RELEASE OF RADIOACTIVE GASEOUS EFFLUENTS
SECOND QUARTER, 2002
ON-SITE DOSE TO MEMBERS OF THE PUBLIC (SPECIAL INTEREST GROUPS)**

Specific Activity	Exposure Location (Sectors)	Exposure Closest Dist (meters)	Exposure Time (Hours)	External Dose			Internal Dose
				Noble Gas		Iodines, Particulates, and Tritium	
				Whole Body	Skin	Ground Plane	
Police at Shooting Range	SE	700	52.0	6.42E-5	9.59E-5	6.09E-6	4.67E-4
Tour Participants							
(a) Simulator Bldg.	S	310	1.00	8.42E-7	1.26E-6	4.23E-8	6.13E-6
(b) Bio Lab	SSE	460	1.50	1.26E-6	1.89E-6	9.61E-8	9.20E-6
(c) Overlook	E	210	0.25	5.86E-7	8.76E-7	1.38E-8	4.27E-6
American Indians	NW	200	24.0	2.32E-4	3.47E-4	6.29E-6	1.69E-3
at Burial Grounds	NNW	200	24.0	1.63E-4	2.43E-4	3.59E-6	1.18E-3
Ranch Hands driving cattle around site							
	NW	250	0.25	1.62E-6	2.43E-6	4.62E-8	1.18E-5
	NNW	350	0.25	6.21E-7	9.29E-7	1.56E-8	4.52E-6
	N	320	0.25	4.13E-7	6.17E-7	7.85E-9	3.01E-6
	NNE	450	0.25	1.61E-7	2.41E-7	3.38E-9	1.18E-6
	NE	630	0.25	8.21E-8	1.23E-7	2.08E-9	5.98E-7

NOTE: All doses are in mrem.

**DIABLO CANYON POWER PLANT
ANNUAL RADIOACTIVE EFFLUENT RELEASE REPORT 2002
TABLE 11C
RADIATION DOSE DUE TO RELEASE OF RADIOACTIVE GASEOUS EFFLUENTS
THIRD QUARTER, 2002
ON-SITE DOSE TO MEMBERS OF THE PUBLIC (SPECIAL INTEREST GROUPS)**

Specific Activity	Exposure Location (Sectors)	Exposure Closest Dist (meters)	Exposure Time (Hours)	External Dose			Internal Dose
				Noble Gas		Iodines, Particulates, and Tritium	
				Whole Body	Skin		
Police at Shooting Range	SE	700	52.0	5.15E-5	7.63E-5	5.66E-7	4.36E-4
Tour Participants (a) Simulator Bldg.	S	310	1.00	6.75E-7	1.00E-6	3.93E-9	5.72E-6
(b) Bio Lab	SSE	460	1.50	1.01E-6	1.50E-6	8.93E-9	8.58E-6
(c) Overlook	E	210	0.25	4.70E-7	6.96E-7	1.28E-9	3.98E-6
American Indians	NW	200	24.0	1.86E-4	2.76E-4	5.85E-7	1.58E-3
at Burial Grounds	NNW	200	24.0	1.30E-4	1.93E-4	3.34E-7	1.11E-3
Ranch Hands driving cattle around site	NW	250	0.25	1.30E-6	1.93E-6	4.30E-9	1.10E-5
	NNW	350	0.25	4.98E-7	7.38E-7	1.45E-9	4.22E-6
	N	320	0.25	3.31E-7	4.90E-7	7.29E-10	2.80E-6
	NNE	450	0.25	1.29E-7	1.92E-7	3.14E-10	1.10E-6
	NE	630	0.25	6.58E-8	9.76E-8	1.93E-10	5.58E-7

NOTE: All doses are in mrem.

**DIABLO CANYON POWER PLANT
ANNUAL RADIOACTIVE EFFLUENT RELEASE REPORT 2002
TABLE 11D
RADIATION DOSE DUE TO RELEASE OF RADIOACTIVE GASEOUS EFFLUENTS
FOURTH QUARTER, 2002
ON-SITE DOSE TO MEMBERS OF THE PUBLIC (SPECIAL INTEREST GROUPS)**

Specific Activity	Exposure Location (Sectors)	Exposure Closest Dist (meters)	Exposure Time (Hours)	External Dose			Internal Dose	
				Noble Gas				Iodines, Particulates, and Tritium
				Whole Body	Skin	Ground Plane		
Police at Shooting Range	SE	700	52.0	5.56E-5	8.80E-5	8.01E-5	6.81E-4	
Tour Participants (a) Simulator Bldg.	S	310	1.00	7.29E-7	1.15E-6	5.56E-7	8.93E-6	
(b) Bio Lab	SSE	460	1.50	1.09E-6	1.73E-6	1.26E-6	1.34E-5	
(c) Overlook	E	210	0.25	5.08E-7	8.04E-7	1.81E-7	6.21E-6	
American Indians at Burial Grounds	NW	200	24.0	2.01E-4	3.19E-4	8.27E-5	2.47E-3	
Ranch Hands driving cattle around site	NNW	200	24.0	1.41E-4	2.23E-4	4.72E-5	1.72E-3	
	NW	250	0.25	1.41E-6	2.23E-6	6.08E-7	1.72E-5	
	NNW	350	0.25	5.38E-7	8.52E-7	2.05E-7	6.59E-6	
	N	320	0.25	3.58E-7	5.66E-7	1.03E-7	4.38E-6	
	NNE	450	0.25	1.40E-7	2.21E-7	4.44E-8	1.71E-6	
	NE	630	0.25	7.12E-8	1.13E-7	2.73E-8	8.71E-7	

NOTE: All doses are in mrem.

**DIABLO CANYON POWER PLANT
ANNUAL RADIOACTIVE EFFLUENT RELEASE REPORT 2002
TABLE 11E
RADIATION DOSE DUE TO RELEASE OF RADIOACTIVE GASEOUS EFFLUENTS
ANNUAL TOTAL, 2002
ON-SITE DOSE TO MEMBERS OF THE PUBLIC (SPECIAL INTEREST GROUPS)**

Specific Activity	Exposure Location (Sectors)	Exposure Closest Dist (meters)	Exposure Time (Hours)	External Dose			Internal Dose
				Noble Gas		Iodines, Particulates, and Tritium	
				Whole Body	Skin		
Police at Shooting Range	SE	700	208.0	3.33E-4	5.12E-4	2.77E-4	1.73E-3
Tour Participants	S	310	4.00	4.37E-6	6.71E-6	1.92E-6	2.27E-5
(a) Simulator Bldg.	SSE	460	6.00	6.55E-6	1.01E-5	4.37E-6	3.41E-5
(b) Bio Lab	E	210	1.00	3.04E-6	4.67E-6	6.28E-7	1.58E-5
(c) Overlook	NW	200	96.0	1.21E-3	1.85E-3	2.86E-4	6.27E-3
American Indians at Burial Grounds	NNW	200	96.0	8.44E-4	1.30E-3	1.63E-4	4.39E-3
Ranch Hands driving cattle around site	NW	250	1	8.42E-6	1.29E-5	2.10E-6	4.38E-5
	NNW	350	1	3.22E-6	4.95E-6	7.09E-7	1.68E-5
	N	320	1	2.14E-6	3.29E-6	3.57E-7	1.11E-5
	NNE	450	1	8.37E-7	1.29E-6	1.54E-7	4.36E-6
	NE	630	1	4.26E-7	6.54E-7	9.46E-8	2.22E-6

NOTE: All doses are in mrem.

XI. Meteorological Data

Meteorological Data

The hour-by-hour listing of wind speed, wind direction, atmospheric stability and precipitation is contained on compact disc with this submittal.

Attachment 1

Radiological Monitoring and Controls Program

(Procedure CY2, Revision 5)

PACIFIC GAS AND ELECTRIC COMPANY
NUCLEAR POWER GENERATION
PROGRAM DIRECTIVE

NUMBER CY2
REVISION 5
PAGE 1 OF 12

TITLE: Radiological Monitoring and Controls Program

10/08/02
EFFECTIVE DATE

CLASSIFICATION: QUALITY RELATED
SPONSORING ORGANIZATION: CHEMISTRY

TABLE OF CONTENTS

<u>SECTION</u>	<u>PAGE</u>
PROGRAM OVERVIEW	1
APPLICABILITY	3
DEFINITIONS	3
PROGRAM OBJECTIVES AND REQUIREMENTS	3
Program Objectives	3
Program Requirements	4
Radiological Environmental Monitoring Program	4
Radioactive Effluent Control Program	4
Offsite Dose Calculation Procedures	6
Environmental Radiological Monitoring Procedure	7
Radwaste Treatment Systems	7
Quality Assurance Requirements	7
RESPONSIBILITIES	8
KEY IMPLEMENTING DOCUMENTS	8
Inter-Departmental Administrative Procedures (IDAPs)	8
Department-Level Administrative Procedures (DLAPs)	8
CLOSELY RELATED PROGRAMS	9
RECORDS	9
APPENDICES	10
ATTACHMENTS	10
REFERENCES	10
SPONSOR	10

1. PROGRAM OVERVIEW

It is the policy of nuclear generation that the release of radioactive materials to the environment be in compliance with Federal regulations and be "As Low As Reasonably Achievable" (ALARA). The overall objectives are to protect the health and safety of the public from undue radiation exposure and to minimize the amount of radioactive effluents resulting from the operation of the plant.

This PD defines the overall policies and general requirements related to the Radiological Monitoring and Controls Program (RMCP). This includes the Radiological Environmental Monitoring Program (REMP), and the Radioactive Effluent Controls Program (RECP).

PACIFIC GAS AND ELECTRIC COMPANY
PROGRAM DIRECTIVE

NUMBER CY2
REVISION 5
PAGE 2 OF 12

TITLE: Radiological Monitoring and Controls Program

The scope of this PD is focused on the control of releases of radioactive material to the environment, and minimizing radiological impact on the general public. Radiation protection of plant workers and visitors within the restricted area of the plant is within the scope of RP1, "Radiation Protection."

Figure 1 illustrates the hierarchy of procedures associated with this PD.

FIGURE 1
CY2
Hierarchy of Procedures

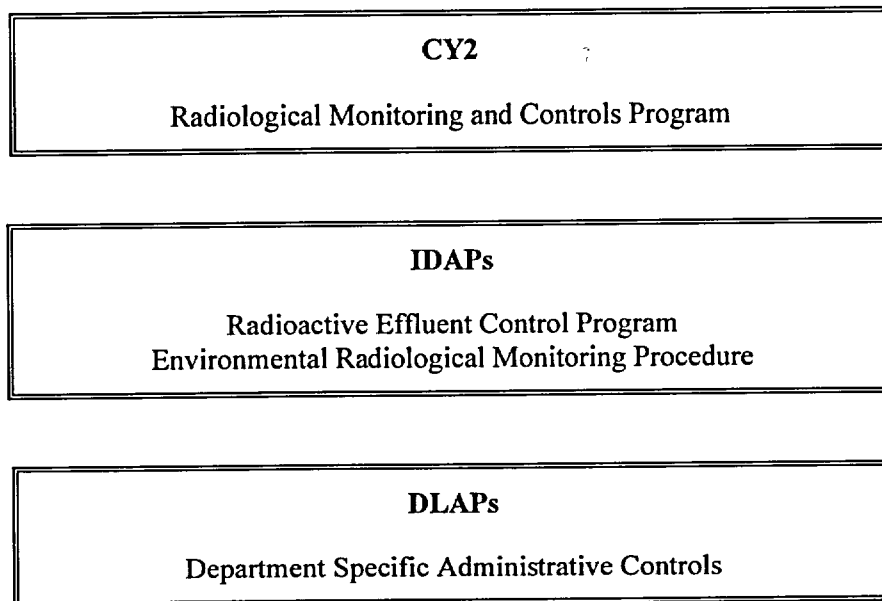

TITLE: Radiological Monitoring and Controls Program

2. APPLICABILITY

This PD is applicable to all persons involved in radioactive effluent control, monitoring, and management activities. This includes all nuclear generation personnel, personnel matrixed to nuclear generation from other company organizations, personnel in other company organizations that are engaged in activities in support of nuclear generation, and contractor personnel that are working under nuclear generation supervision.

3. DEFINITIONS

3.1 ALARA (acronym for "as low as reasonably achievable") - A term that means making every reasonable effort to maintain exposures to radiation as far below the dose limits of 10 CFR 20 as is practical consistent with the purpose for which the licensed activity is undertaken, taking into account the state of technology, the economics of improvements in relation to state of technology, the economics of improvements in relation to benefits to the public health and safety, and in relation to utilization of nuclear energy and licensed materials in the public interest. The specific objectives of achieving ALARA effluents are based on those described in 10 CFR 50, Appendix I.

3.2 The Radiological Monitoring and Controls Program (RMCP) - Contains the Radioactive Effluent Controls and Radiological Environmental Monitoring Programs required by Technical Specifications 5.5.1 and 5.5.4 and descriptions of the information that should be included in the Annual Radiological Environmental Operating and Annual Radioactive Effluent Release Reports required by Technical Specifications 5.6.2 and 5.6.3.

3.3 Offsite Dose Calculation Procedure (ODCP) - Contains the methodology and parameters used in the calculation of offsite doses due to radioactive gaseous and liquid effluents and in the calculation of gaseous and liquid effluent monitoring Alarm/Trip Setpoints.

3.4 Environmental Radiological Monitoring Procedure (ERMP) - Contains a description of sample locations, types of sample locations, methods and frequency of analysis, and reporting requirements.

4. PROGRAM OBJECTIVES AND REQUIREMENTS

4.1 Program Objectives

The nuclear generation radiological monitoring and controls program is established to meet the following objectives:

4.1.1 Ensure that systems, methods, and controls are established to meet applicable regulatory requirements and objectives for release of radioactive effluents.

Liquid and gaseous radioactive waste processing systems provide the means for controlling radioactive releases. It is also important to establish administrative controls with clear delineation of responsibilities to ensure that monitoring, measurement, and release activities are properly sequenced, authorized, and controlled.

TITLE: Radiological Monitoring and Controls Program

4.2 Program Requirements

The basic requirement for the radiological monitoring and controls program shall be to maintain radioactive releases to the unrestricted areas surrounding the plant in conformance with applicable Federal regulations and ALARA. The following sections provide additional requirements for various elements of the program.

4.2.1 Changes to the RMCP (including ODCP, ERMP and RECP) shall be processed in accordance with the requirements of the plant Technical Specification Section 5.5.1.

4.2.2 Radiological Environmental Monitoring Program

- a. A Radiological Environmental Monitoring Program (REMP) shall be established and maintained to comply with the plant Technical Specification 5.5.1, Radiological Environmental Monitoring Program requirements. The program shall be provided to monitor the radiation and radionuclides in the environs of the plant, and shall address the following:
1. Monitoring, sampling, analysis, and reporting of radiation and radionuclides in the environment in accordance with the methodology and parameters in the Environmental Radiological Monitoring Procedure (ERMP),
 2. A Land Use Census to ensure that changes in the use of areas at and beyond the SITE BOUNDARY are identified and that modifications to the monitoring program are made if required by the results of this census, and
 3. Participation in an Interlaboratory Comparison Program to ensure that independent checks on the precision and accuracy of the measurements of radioactive materials in the environmental sample matrices are performed as part of the quality assurance program for environmental monitoring.

4.2.3 Radioactive Effluent Control Program

- a. Monitoring requirements shall be established and maintained for all major and potentially significant paths for release of radioactive material during normal plant operation, including anticipated operational occurrences, to comply with Regulatory Guide 1.21, Revision 1, June 1974, requirements.

TITLE: Radiological Monitoring and Controls Program

- b. Procedures shall be established and maintained to define the methods and requirements for control of liquid and gaseous radioactive discharges within the limits of the plant Technical Specification Section 5.5.4. These procedures shall address the following:
1. Limitations on the operability of radioactive liquid and gaseous monitoring instrumentation including surveillance requirements and setpoint determination in accordance with methodology in the Offsite Dose Calculation Procedure, (ODCP),
 2. Limitations on the concentrations of radioactive material released in liquid effluents to UNRESTRICTED AREAS conforming to 10 CFR Part 20, Appendix B, Table 2, Column 2,
 3. Monitoring, sampling, and analysis of radioactive liquid and gaseous effluents in accordance with 10 CFR 20.1302 and with the methodology and parameters in the ODCP,
 4. Limitations on the annual and quarterly doses or dose commitment to a MEMBER OF THE PUBLIC from radioactive materials in liquid effluents released from each unit to UNRESTRICTED AREAS conforming to Appendix I to 10 CFR Part 50,
 5. Determination of cumulative and projected dose contributions from radioactive effluents for the current calendar quarter and current calendar year in accordance with the methodology and parameters in the ODCP at least every 31 days,
 6. Limitations on the operability and use of the liquid and gaseous effluent treatment systems to ensure that the appropriate portions of these systems are used to reduce releases of radioactivity when the projected doses in a 31-day period would exceed 2 percent of the guidelines for the annual dose or dose commitment conforming to Appendix I to 10 CFR Part 50,
 7. Limitations on the dose rate resulting from radioactive material released in gaseous effluents from the site to areas at or beyond the SITE BOUNDARY shall be limited to the following:
 - a) For noble gases: Less than or equal to a dose rate of 500 mrem/yr to the whole body and less than or equal to a dose rate of 3000 mrem/yr to the skin, and
 - b) For Iodine-131, for Iodine-133, for tritium, and for all radionuclides in particulate form with half-lives greater than 8 days: Less than or equal to a dose rate of 1500 mrem/yr to any organ.

TITLE: Radiological Monitoring and Controls Program

8. Limitations on the annual and quarterly air doses resulting from noble gases released in gaseous effluents from each unit to areas beyond the SITE BOUNDARY conforming to Appendix I to 10 CFR Part 50,
 9. Limitations on the annual and quarterly doses to MEMBERS OF THE PUBLIC from Iodine-131, Iodine-133, tritium, and all radionuclides in particulate form with half-lives greater than 8 days in gaseous effluents released from each unit to areas beyond the SITE BOUNDARY conforming to Appendix I to 10 CFR Part 50, and
 10. Limitations on the annual dose or dose commitment to any MEMBER OF THE PUBLIC due to releases of radioactivity and to radiation from uranium fuel cycle sources conforming to 40 CFR Part 190.
 11. The provisions of SR 3.0.2 and SR 3.0.3 are applicable to the Radioactive Effluent Controls Program Surveillance Frequency.
- c. Sampling and analysis methods associated with effluent monitoring activities shall be controlled in accordance with a department level administrative procedure that controls material and equipment used for analysis for the chemistry and radiochemistry programs.
 - d. Systems that are known pathways for radioactive releases shall be explicitly addressed. Periodic sampling of systems with the potential of becoming radioactively contaminated should also be addressed.
 - e. An onsite meteorological program shall be established and maintained in accordance with the requirements of Regulatory Guide 1.23, February 1972, to provide sufficient data for the performance of dose assessments.
 - f. The collection and processing of technical data required to support the Annual Radioactive Effluent Release Report and non-routine reports to the NRC to comply with the plant Technical Specification 5.6.3 shall be defined as part of this program. The processing of these reports shall be performed in accordance with XI1, "Regulatory Interface."

4.2.4 Offsite Dose Calculation Procedures

- a. Offsite Dose Calculation Procedures (ODCP) shall be established and maintained to define and control the methods for determining offsite doses. NRC Regulatory Guide 1.109, Revision 1, October 1977, as well as its interpretation through NUREG 0133, should be used as guidance for establishing acceptable methods. These procedures shall address the following:

TITLE: Radiological Monitoring and Controls Program

1. Methods for determining monitoring instrumentation alarm setpoints are addressed in accordance with a Department-Level Administrative Procedure (DLAP) under CY2.
 2. Methods for determining effluent concentrations.
 3. Methods for calculating doses to persons in unrestricted areas surrounding the plant from all exposure pathways.
- b. Changes to the ODCP shall be processed in accordance with the requirements of Technical Specification 5.5.1.

4.2.5 Environmental Radiological Monitoring Procedure

- a. An Environmental Radiological Monitoring Procedure (ERMP) shall be established and shall contain a description of sample locations, types of sample locations, methods and frequency of analysis, and reporting requirements.

4.2.6 Radwaste Treatment Systems

- a. Radwaste Treatment Systems shall be provided to control the processing and release of radioactive materials in gaseous and liquid effluent in compliance with Technical Specification requirements. The design of these systems shall be controlled in accordance with CF3, "Design Control," and the requirements of Regulatory Guide 1.143, October 1979.
- b. Approval of changes to the radwaste treatment systems shall be processed in accordance with the requirements of CF4, "Modification Control."

4.2.7 Quality Assurance Requirements

In addition to requirements specified in earlier sections and those requirements utilizing procedures in the section 6.2 of this PD, the control program shall be subject to the quality assurance requirements specified in CY1, "Chemistry/Radiochemistry."

4.3 Support by the Company Departments

Departments outside of nuclear generation may be called upon to support nuclear generation activities associated with the Radioactive Monitoring Controls Program. The contract or agreement between nuclear generation and other departments shall ensure the support is performed in accordance with the requirements of this PD.

EXAMPLE: The technical and ecological director may perform radiological laboratory analysis for the Radiological Environmental Monitoring Program and prepare and review the Annual Radiological Environmental Operating Report, in accordance with this PD.

TITLE: Radiological Monitoring and Controls Program

5. RESPONSIBILITIES

- 5.1 The chief nuclear officer - is responsible for establishing the policy and general requirements for the Radiological Monitoring and Controls Program, for providing management support and guidance for the program's implementation, and ensuring compliance with all regulatory requirements is maintained.
- 5.2 The plant operations vice president - is responsible for the overall development, implementation, and maintenance of the Radiological Monitoring and Controls Program in accordance with the requirements of this PD.
- 5.3 The plant services vice president - is responsible for ensuring that support from reporting departments is provided for the Radiological Monitoring and Controls Program.
- 5.4 The station director - is responsible for the direct implementation of the Radiological Monitoring and Controls Program with the exception of the design of radwaste treatment and effluent monitoring systems.
- 5.5 The engineering director - is responsible for maintaining the design bases for installed plant radwaste treatment and effluent monitoring systems, structures, and components and providing technical support to the plant for the operation and maintenance of these systems.
- 5.6 The licensing director - is responsible for auditing the Radiological Monitoring and Controls Program as outlined in step 3.10 of Appendix 9.1.
- 5.7 The maintenance director - is responsible for maintaining the radiation monitoring systems and the hardware and software for the Rad Effluent program.

6. KEY IMPLEMENTING DOCUMENTS

- 6.1 Inter-Departmental Administrative Procedures (IDAPs)
Inter-Department Administrative Procedures shall be developed to address the following aspects of the Radiological Monitoring and Controls Program:
 - 6.1.1 An IDAP shall be developed to define the requirements and responsibilities associated with the Radioactive Effluent Control Program.
 - 6.1.2 An IDAP shall be developed to define the requirements and responsibilities associated with the Environmental Radiological Monitoring Procedure.
- 6.2 Department-Level Administrative Procedures (DLAPs)
Departments responsible for performing activities related to the Radioactive Effluent Control program shall develop DLAPs as appropriate to control program activities.

TITLE: Radiological Monitoring and Controls Program

7. CLOSELY RELATED PROGRAMS

7.1 Interfaces

This section describes each of the principal interfaces and boundaries between this Program Directive and other management processes.

7.1.1 AD10, "Records"

"Records" provides for the retention of Radiological Monitoring and Controls Program records.

7.1.2 CF3, "Design Control"

"Design Control" addresses the implementation of design activities for installed radwaste treatment and effluent monitoring systems in accordance with the requirements of NRC Regulatory Guide 1.143.

7.1.3 CF4, "Modification Control"

"Modification Control" addresses the implementation of modification activities for installed effluent monitoring systems.

7.1.4 CY1, "Chemistry/Radiochemistry"

"Chemistry/Radiochemistry" addresses the methods for chemistry/radiochemistry sampling and analysis of liquid and gaseous radioactive effluents in support of this PD.

7.1.5 OM7, "Problem Resolution"

"Problem Resolution" addresses deficiencies identified during the implementation of the radioactive effluent control program. OM7 also addresses evaluating nonconformances for reportability in accordance with Technical Specifications.

7.1.6 TQ1, "Personnel Training and Qualification"

"Personnel Training and Qualification" identifies training and qualification requirements for personnel.

7.1.7 XI1, "Regulatory Interface"

"Regulatory Interface" addresses the process for required reporting and communication with outside agencies.

7.1.8 CY2.ID1, "Radioactive Effluent Controls Program"

"Radioactive Effluent Controls Program" contains the general program requirements to ensure the requirements of 10 CFR Part 20 and 10 CFR Part 50, Appendix I, are met.

8. RECORDS

None

PACIFIC GAS AND ELECTRIC COMPANY
PROGRAM DIRECTIVE

NUMBER CY2
REVISION 5
PAGE 10 OF 12

TITLE: Radiological Monitoring and Controls Program

9. APPENDICES

9.1 Graded Quality Assurance Requirements for Radiological Monitoring and Controls Program

10. ATTACHMENTS

None

11. REFERENCES

11.1 Title 10, Code of Federal Regulations,

11.1.1 Part 20, "Standards for Protection Against Radiation"

11.1.2 Part 50, Appendix I,

11.1.3 Part 50, Appendix A, GDC 60, 64,

11.1.4 Part 50.36a, "Technical Specifications on Effluents from Nuclear Power Reactors"

11.2 Title 40, Code of Federal Regulations, "Environmental Radiation Protection Standards for Nuclear Power Operations."

11.3 Regulatory Guide 1.109, Revision 1, October 1977, "Calculation of Annual Doses to Man From Routine Releases of Reactor Effluents for the Purpose of Evaluating Compliance with 10 CFR Part 50 Appendix I."

11.4 Regulatory Guide 1.143, October 1979, "Design Guidance for Radioactive Waste Management Systems, Structures, and Components Installed in Light-Water-Cooled Nuclear Power Plants."

11.5 Regulatory Guide 1.21, Revision 1, June 1974, "Measuring, Evaluating, and Reporting Radioactivity in Solid Wastes and Releases of Radioactive Materials in Liquid and Gaseous Effluent from Light-Water-Cooled Nuclear Power Plants."

11.6 Regulatory Guide 1.23, February 1972, "Onsite Meteorological Programs."

11.7 Regulatory Guide 4.15, Revision 1, February 1979, "Quality Assurance For Radiological Monitoring Programs (Normal Operations) - Effluent Streams and the Environment."

11.8 Regulatory Guide 4.1, Revision 1, April 1975, "Programs for Monitoring Radioactivity in the Environs of Nuclear Power Plants."

11.9 Diablo Canyon Nuclear Power Plant Facility Operating Licenses (Unit 1, Unit 2)

11.10 QA Commitment: FSAR Chapter 17.2.

11.11 QA Commitment: Regulatory Guide 1.33.

12. SPONSOR

John Knemeyer

PACIFIC GAS AND ELECTRIC COMPANY
PROGRAM DIRECTIVE

NUMBER CY2
REVISION 5
PAGE 11 OF 12

TITLE: Radiological Monitoring and Controls Program

APPENDIX 9.1

GRADED QA REQUIREMENTS
FOR RADIOLOGICAL MONITORING AND CONTROLS PROGRAM

The basis for these Graded QA requirements is to comply with the regulations of 10 CFR 20, 10 CFR 50, 40 CFR 190, the Technical Specifications and Regulatory Guides 1.21, and 4.15.

1. GRADED ITEMS

Radioactive Effluent monitoring instruments are classified as Category 2 or Category 3 items per Regulatory Guide 1.97, "Instrumentation for Light-Water-Cooled Nuclear Power Plants to Assess Plant and Environs Conditions During and Following an Accident." These instruments are used for detection and assessment of releases and possibly detection of containment breach with accomplishment of mitigation of the breach. These items fall under Graded QA requirements.

2. GRADED ACTIVITIES

- 2.1 Installed radiation monitors required per Technical Specification 3.3.3 for monitoring radioactive effluents during plant operations or accidents shall be calibrated at prescribed intervals.
- 2.2 Sampling and analysis of liquid and gaseous effluents shall be performed in accordance with CY1, "Chemistry/Radiochemistry."
- 2.3 Calculations, computer programs, and procedures for evaluating the dose associated with radioactive effluents shall be performed in accordance with approved quality related procedures.

3. GRADED REQUIREMENTS

- 3.1 Effluent releases shall be maintained ALARA and shall be performed in accordance with the requirements of this Program Directive (CY2) to limit the concentrations, doses and doserates as specified in DCPD Technical Specification 5.5.4, NRC regulations 10 CFR 20, 10 CFR 50 Appendix I, and EPA regulation 40 CFR 190.
- 3.2 The Annual Radiological Environmental Operating Report shall be developed in accordance with Technical Specification 5.6.2.
- 3.3 The Annual Radioactive Effluent Release Report shall be developed in accordance with Technical Specification 5.6.3.
- 3.4 Records that support and document the Radiological Monitoring and Controls Program shall be controlled in accordance with AD10, "Records."
- 3.5 Personnel involved in direct implementation of chemistry/radiochemistry, operations, or radiation protection activities in support of the Radiological Monitoring and Controls Program are qualified in accordance with the requirements of TQ1, "Personnel Training and Qualification." In addition, personnel involved in direct implementation of activities in support of the Radiological Environmental Monitoring Program are qualified in accordance with the requirements of an interdepartmental administrative procedure for Environmental Radiological Monitoring (ERMP).

TITLE: Radiological Monitoring and Controls Program

APPENDIX 9.1 (Continued)

- 3.6 Notifications and reports to and correspondence with regulatory agencies shall be done in accordance with XI1, "Regulatory Interface."
- 3.7 Written plans, procedures and instructions for implementing Radiological Monitoring and Controls Program shall be prepared, processed, and controlled in accordance with AD1, "Administrative Control Program."
- 3.8 Procurement of quality-related equipment or services shall be in accordance with written procedures. Applicable regulatory requirements, design bases, and any other requirements necessary to assure adequate quality shall be included in or invoked by reference in documents for procurement of items or services. Test or acceptance requirements and documentation to be submitted by the supplier shall be identified in the procurement documents. Receipt inspection requirements, if required, shall be identified in the procurement documents.
- 3.9 Deficiencies identified during implementation of this program shall be documented and controlled in accordance with OM7, "Problem Resolution."
- 3.10 FSAR Chapter 17.18, "Audits," prescribes the audit frequency for various portions of the RMCP:
 - 3.10.1 The performance of activities required by the quality assurance program for the Radioactive Effluents Control Program shall be audited at least once per 24 months unless specified otherwise.
 - 3.10.2 The Radiological Environmental Monitoring Program, implementing procedures, and program results shall be audited at least once per 24 months.
 - 3.10.3 The Offsite Dose Calculation Procedure and its implementing procedures shall be audited at least once per 24 months.

Attachment 2

Radioactive Effluent Controls Program

(Procedure CY2.ID1, Revision 6A)

PACIFIC GAS AND ELECTRIC COMPANY
NUCLEAR POWER GENERATION
INTER-DEPARTMENTAL ADMINISTRATIVE PROCEDURE

NUMBER CY2.ID1
REVISION 6A
PAGE 1 OF 39

TITLE: Radioactive Effluent Controls Program

02/01/02
EFFECTIVE DATE

PROCEDURE CLASSIFICATION: QUALITY RELATED
SPONSORING ORGANIZATION: CHEMISTRY
REVIEW LEVEL: "A"

TABLE OF CONTENTS

<u>SECTION</u>	<u>PAGE</u>
<u>SCOPE</u>	1
<u>DISCUSSION</u>	1
<u>RESPONSIBILITIES</u>	2
<u>INSTRUCTIONS</u>	3
<u>RECORDS</u>	7
<u>APPENDICES</u>	7
<u>REFERENCES</u>	7
<u>SPONSOR</u>	7

1. SCOPE

1.1 This procedure contains the general program requirements of the Radioactive Effluent Controls Program. This program ensures that the requirements of 10 CFR Part 20 and 10 CFR Part 50 Appendix I are met.

2. DISCUSSION

2.1 This procedure provides the general requirements for Radioactive Effluent Controls Program in accordance with the Technical Specifications and the implementation Generic Letter 89-01, "Implementation of Programmatic Controls for Radiological Effluent Technical Specifications in the Administrative Controls Section of the Technical Specifications and the Relocation of Procedural Details of RETS to the Off-Site Dose Calculation Manual or to the Process Control Program."

2.2 The following Technical Specification definitions are applicable: T.S. Section 5.5.1

2.2.1 The Offsite Dose Calculation Manual (ODCM) shall contain the methodology and parameters used in the calculation of offsite doses resulting from radioactive gaseous and liquid effluents, in the calculation of gaseous and liquid effluent monitoring alarm and trip setpoints, and in the conduct of radiological environmental monitoring program; and

2.2.2 The ODCM shall contain the radioactive effluent controls and radiological environmental monitoring activities, and the description of the information that should be included in the Annual Radiological Environmental Operating, and the Radioactive Effluent Release Reports required by Technical Specification 5.6.2 and 5.6.3.

TITLE: Radioactive Effluent Controls Program

2.2.3 The Diablo Canyon ODCM is made up of the following procedures:

CAP A-8, "Offsite Dose Calculation Procedure"

CY2.ID1, "Radioactive Effluent Controls Program"

RP1.ID11, "Environmental Radiological Monitoring Procedure"

CY2, "Radiological Monitoring and Controls Program"

Changes to each of these procedures shall be processed in accordance with the requirements of Technical Specification Section 5.5.1.

2.3 The specific methodology and parameters used in the calculation of off-site doses resulting from radioactive gaseous and liquid effluents and in the calculation of gaseous and liquid effluent monitoring Alarm/Trip Setpoints, is contained in CAP A-8, "Off-Site Dose Calculations Procedure (ODCP)." As such, CAP A-8 is incorporated in this procedure by reference. Therefore, the requirements for revisions to this procedure also apply to CAP A-8.

3. RESPONSIBILITIES

3.1 The chemistry manager is responsible for:

3.1.1 Implementation of the Off-Site Dose Calculation Procedure in a manner that meets regulatory requirements and preparing the Annual Radiological Effluent Release Report.

3.1.2 Providing direction to the Operations Staff in the processing of radioactive waste streams.

3.1.3 Ensuring that a comparison of the Annual Radioactive Effluent Release Report and the Annual Radiological Environmental Operating Report is performed.

3.1.4 Ensuring that dose commitment increases due to the Land Use Census in accordance with Commitment 6.1.12.1 are determined and communicated promptly to radiation protection.

3.2 The radiation protection manager is responsible for:

3.2.1 Ensuring the performance of the annual land use census and that the results are provided to Chemistry so that Chemistry can establish the dose requirements of Commitment 6.1.12.1.

3.2.2 Ensuring that the results of the annual Land Use Census are provided to TES for inclusion in the Annual Radiological Environmental Operating Report.

PACIFIC GAS AND ELECTRIC COMPANY
INTER-DEPARTMENTAL ADMINISTRATIVE PROCEDURE

NUMBER CY2.ID1
REVISION 6A
PAGE 3 OF 39

TITLE: Radioactive Effluent Controls Program

3.2.3 Ensuring that changes to the Environmental Radiological Monitoring Procedure are provided to Chemistry for inclusion in the Annual Radiological Effluent Release Report.

3.2.4 Ensuring preparation, review and approval of the Nonroutine Radiological Environmental Operating Report when required by Commitment 6.1.11.1

3.3 TES is responsible for ensuring that REMP sample results exceeding the criteria of Commitment 6.1.11.1 are communicated promptly to the chemistry manager and the radiation protection manager at the plant.

4. INSTRUCTIONS

4.1 Administrative Requirements

4.1.1 Appendix 6.1 of this procedure contains the operational requirements of the Radioactive Effluent Controls Program.

4.1.2 The operational requirements are implemented by equipment control guidelines (reference OP1.DC16), CAP A-8, and XI1.ID2, "Regulatory Reporting Requirements and Reporting Process."

- a. The Equipment Control Guidelines implement those requirements that are related to equipment and have specific allowed outage times or operator actions.
- b. CAP A-8 includes the methodology and parameters used in the calculation of off-site doses resulting from radioactive gaseous and liquid effluents and in the calculation of gaseous and liquid effluent monitoring alarm/trip setpoints.
- c. XI1.ID2 implements the reporting requirements.

4.2 Reporting Requirements

4.2.1 Annual Radioactive Effluent Release Report

a. Report Schedule

1. Annual Radioactive Effluent Release Reports covering the operation of the unit during the previous calendar year shall be submitted before May 1 of each year, in accordance with 10CR50.36a.

TITLE: Radioactive Effluent Controls Program

- b. The Annual Radioactive Effluent Release Reports shall include:
1. A summary of the quantities of radioactive liquid and gaseous effluents and solid waste released from the unit as outlined in Regulatory Guide 1.21, "Measuring, Evaluating, and Reporting Radioactivity in Solid Wastes and Releases of Radioactive Materials in Liquid and Gaseous Effluents from Light-Water-Cooled Nuclear Power Plants," Revision 1, June 1974, with data summarized on a quarterly basis following the format of Appendix B thereof. For solid wastes, the format for Table 3 in Appendix B shall be supplemented with three additional categories; class of solid wastes (as defined by 10 CFR Part 61), type of container (e.g., LSA, Type A, Type B, Large Quantity) and SOLIDIFICATION agent or absorbent (e.g., cement, urea formaldehyde);
 2. A list and description of unplanned releases as defined in ODCP from the site to UNRESTRICTED AREAS of radioactive materials in gaseous and liquid effluents made during the reporting period;
 3. Pursuant to Technical Specification 5.5.1, any changes made during the reporting period to the following:
 - RP2.DC2, "Process Control Program (PCP)"
 - CY2.ID1, "Radioactive Effluent Controls Program (RECP)"
 - CY2, "Radiological Monitoring and Controls Program (RMCP)"
 - RP1.ID11, "Environmental Radiological Monitoring Program (ERMP)"
 - CAP A-8, "Offsite Dose Calculation Procedure (ODCP)"

NOTE: An FSAR update may be used in lieu of the ARERR for communicating changes to the NRC, regarding the PCP.
 4. A listing of new locations for dose calculations and/or environmental monitoring identified by the Land Use Census pursuant to Appendix 6.1.
 5. An explanation as to why the inoperability of liquid or gaseous effluent monitoring instrumentation was not corrected within the time specified in Appendix 6.1; and
 6. Description of the events leading to liquid holdup tanks or gas storage tanks exceeding the limits of ECG 19.1 or ECG 24.3.

TITLE: Radioactive Effluent Controls Program

- c. A discussion of major changes to the Radwaste Treatment Systems (liquid, gaseous and solid). The discussion of each change shall contain:
1. A summary of the evaluation that led to the determination that the change could be made in accordance with 10 CFR 50.59;
 2. Sufficient detailed information to totally support the reason for the change without benefit of additional or supplemental information;
 3. A detailed description of the equipment, components and processes involved and the interfaces with other plant systems;
 4. An evaluation of the change which shows the predicted releases of radioactive materials in liquid and gaseous effluents and/or quantity of solid waste that differ from those previously predicted in the License application and amendments thereto;
 5. An evaluation of the change which shows the expected maximum exposures to a MEMBER OF THE PUBLIC in the UNRESTRICTED AREA and to the general population that differ from those previously estimated in the License application and amendments thereto;
 6. A comparison of the predicted releases of radioactive materials, in liquid and gaseous effluents and in solid waste, to the actual releases for the period prior to when the changes are to be made;
 7. An estimate of the exposure to plant operating personnel as a result of the change; and
 8. Documentation of the fact that the change was reviewed and found acceptable by the PSRC.

Otherwise the above information may be submitted as part of the annual FSAR update.

- d. In addition, the Annual Radioactive Effluent Release Report shall also include:
1. An annual summary of hourly meteorological data collected over the previous year. This annual summary may be either in the form of an hour-by-hour listing on magnetic tape/hard disk or other media of wind speed, wind direction, atmospheric stability, and precipitation (if measured), or in the form of joint frequency distributions of wind speed, wind direction, and atmospheric stability or the licensee has the option of retaining this summary of required meteorological data on site in a file that shall be provided to the NRC upon request;

TITLE: Radioactive Effluent Controls Program

2. An assessment of the radiation doses due to the radioactive liquid and gaseous effluents released from the unit or station during the previous calendar year;
 3. An assessment of the radiation doses from radioactive liquid and gaseous effluents to MEMBERS OF THE PUBLIC due to their activities inside the SITE BOUNDARY (see FSAR Figure 2.1-2) during the report period;
 4. All assumptions used in making these assessments, i.e., specific activity, exposure time and location. The meteorological conditions concurrent with the time of release of radioactive materials in gaseous effluents, as determined by sampling frequency and measurement, shall be used for determining the gaseous pathway doses. The assessment of radiation doses shall be performed in accordance with the methodology and parameters in the OFF-SITE DOSE CALCULATION PROCEDURE (ODCP); and
 5. An assessment of radiation doses to the likely most exposed MEMBER OF THE PUBLIC from reactor releases and other nearby uranium fuel cycle sources, including doses from primary effluent pathways and direct radiation, for the previous calendar year to show conformance with 40 CFR Part 190, "Environmental Radiation Protection Standards for Nuclear Power Operation." Acceptable methods for calculating the dose contribution from liquid and gaseous effluents are given in Regulatory Guide 1.109, Rev. 1, October 1977.
- e. A single submittal may be made for a multiple unit plant. The submittal should combine those sections that are common to all units at the plant; however, for units with separate radwaste system, the submittal shall specify the releases of radioactive material from each unit.

4.3 Revisions to the RECP

4.3.1 The requirements for revision to the RECP also apply to CAP A-8.

4.3.2 The requirements are provided in Technical Specification 5.5.1.

4.4 Major changes to Liquid, Gaseous, and Solid Radwaste Treatment Systems

4.4.1 Major changes to the liquid, gaseous, and solid radwaste treatment systems shall become effective upon review and acceptance by the PSRC provided the change could be made in accordance with 10 CFR 50.59.

PACIFIC GAS AND ELECTRIC COMPANY
INTER-DEPARTMENTAL ADMINISTRATIVE PROCEDURE

NUMBER CY2.ID1
REVISION 6A
PAGE 7 OF 39

TITLE: Radioactive Effluent Controls Program

5. RECORDS

5.1 Data Sheets and records will be maintained in the Records Management System (RMS) in accordance with CY1.DC1, "Analytical Data Processing Responsibilities."

6. APPENDICES

6.1 Operational Requirements of the Radioactive Effluent Controls Program

6.2 High Alarm Setpoints for Fuel Building and Control Room Ventilation Systems Actuation Instrumentation

7. REFERENCES

7.1 CAP A-8, "Off-site Dose Calculation Procedure (ODCP)."

7.2 CAP A-5, "Liquid Radwaste Discharge Management."

7.3 CAP A-6, "Gaseous Radwaste Discharge Management."

7.4 RP1.ID11, "Environmental Radiological Monitoring Procedure."

7.5 OP1.DC16, "Control of Plant Equipment Not Required by the Technical Specifications."

7.6 XI1.ID2, "Regulatory Reporting Requirements and Reporting Process."

7.7 Regulatory Guide 1.21, Revision 1, June 1974.

7.8 Regulatory Guide 1.109, Revision 1, October 1977.

7.9 License Amendment Request 93-04.

7.10 10CFR20.1302

7.11 40CFR190

7.12 10CFR50.36a

7.13 10CFR50 Appendix I

7.14 CY2, "Radiological Monitoring and Controls Program"

7.15 QA Commitment: FSAR Chapter 17.2.

7.16 QA Commitment: Reg Guide 4.15.

8. SPONSOR

John Knemeyer

TITLE: Radioactive Effluent Controls Program

APPENDIX 6.1

OPERATIONAL REQUIREMENTS OF THE RADIOACTIVE EFFLUENT
CONTROLS PROGRAM

6.1.1 Radioactive Liquid Effluent Monitoring Instrumentation (Also covered by ECG 39.3)

Commitment for Operation

- 6.1.1.1 The radioactive liquid effluent monitoring instrumentation channels shown in Table 6.1.1-1 shall be OPERABLE with their Alarm/Trip Setpoints set to ensure that the limits of Commitment 6.1.3.1 are not exceeded. The Alarm/Trip Setpoints of these channels shall be determined in accordance with the methodology and parameters in the OFF-SITE DOSE CALCULATION PROCEDURE (ODCP).

Applicability: At all times.

Action:

- a. With a radioactive liquid effluent monitoring instrumentation channel Alarm/Trip Setpoint less conservative than required by the above Commitment, immediately suspend the release of radioactive liquid effluents monitored by the affected channel or declare the channel inoperable.
- b. With less than the minimum number of radioactive liquid effluent monitoring instrumentation channels OPERABLE, take the ACTION shown in Table 6.1.1-1. Restore the inoperable instrumentation to OPERABLE status within the time specified in the ACTION, or explain in the next Annual Radioactive Effluent Release Report why this inoperability was not corrected within the time specified.

Surveillance Requirements

- 6.1.1.2 Each radioactive liquid effluent monitoring instrumentation channel shall be demonstrated OPERABLE by performance of the CHANNEL CHECK, SOURCE CHECK, CHANNEL CALIBRATION and CHANNEL FUNCTIONAL TEST at the frequencies shown in Table 6.1.1-2.
- 6.1.1.3 At least one saltwater pump shall be determined operating and providing dilution to the discharge structure at least once per 4 hours whenever dilution is required to meet the limits of Commitment 6.1.3.1.

TITLE: Radioactive Effluent Controls Program

APPENDIX 6.1 (Continued)

TABLE 6.1.1-1

RADIOACTIVE LIQUID EFFLUENT MONITORING INSTRUMENTATION

<u>INSTRUMENT</u>	<u>MINIMUM CHANNELS OPERABLE</u>	<u>ACTION</u>
1. Radioactivity Monitors Providing Alarm and Automatic Termination of Release		
a. Liquid Radwaste Effluent Line (RM-18)#	1	1
b. Steam Generator Blowdown Tank (RM-23)	1	2
2. Flow Rate Measurement Devices		
a. Liquid Radwaste Effluent Line (FR-20)#	1	4
b. Steam Generator Blowdown Effluent Lines (FR-53)	1	4
c. Oily Water Separator Effluent Line (FR-251)#	1	4
3. Radioactivity Monitor Not Providing Automatic Termination of Release		
Oily Water Separator Effluent Line (RM-3)#	1	3

This Radioactive Liquid Effluent Monitoring Instrumentation is common to both units.

TITLE: Radioactive Effluent Controls Program

APPENDIX 6.1 (Continued)

TABLE 6.1.1-1 (Continued)

ACTION STATEMENTS

- ACTION 1** With the number of channels OPERABLE less than required by the Minimum Channels OPERABLE requirement, effluent releases via this pathway may continue for up to 14 days provided that prior to initiating a release:
- a. At least two independent samples are analyzed in accordance with Commitment 6.1.3.2.
 - b. At least two technically qualified members of the facility staff independently verify the release rate calculations and discharge line valvings.
- Otherwise, suspend release of radioactive effluents via this pathway.
- ACTION 2** With the number of channels OPERABLE less than required by the Minimum Channels OPERABLE requirement, effluent releases via this pathway may continue for up to 30 days provided grab samples are analyzed for radioactivity (beta or gamma) at a lower limit of detection of no more than 10^{-7} microcuries/ml:
- a. At least once per 12 hours when the specific activity of the secondary coolant is greater than 0.01 microcuries/gram DOSE EQUIVALENT I-131, or
 - b. At least once per 24 hours when the specific activity of the secondary coolant is less than or equal to 0.01 microcuries/gram DOSE EQUIVALENT I-131.
- ACTION 3** With the number of channels OPERABLE less than required by the Minimum Channels OPERABLE requirement, effluent releases via this pathway may continue for up to 30 days provided that, at least once per 12 hours, grab samples are collected and analyzed for radioactivity (beta or gamma) at a lower limit of detection of no more than 10^{-7} microcuries/ml or transfer the oily water separator effluent to the Liquid Radwaste Treatment System.
- ACTION 4** With the number of channels OPERABLE less than required by the Minimum Channels OPERABLE requirement, effluent releases via this pathway may continue for up to 30 days provided the flow rate is estimated at least once per 4 hours during actual releases. Pump performance curves may be used to estimate flow.

PACIFIC GAS AND ELECTRIC COMPANY
 INTER-DEPARTMENTAL ADMINISTRATIVE PROCEDURE

NUMBER CY2.ID1
 REVISION 6A
 PAGE 11 OF 39

TITLE: Radioactive Effluent Controls Program

APPENDIX 6.1. (Continued)

TABLE 6.1.1-2
RADIOACTIVE LIQUID EFFLUENT MONITORING INSTRUMENTATION SURVEILLANCE
REQUIREMENTS

<u>Instrument</u>	<u>Channel Check</u>	<u>Source Check</u>	<u>Channel Calibration</u>	<u>Channel Functionality Test</u>
1. Radioactivity Monitors Providing Alarm and Automatic Termination of Release				
a. Liquid Radwaste Effluent Line (RM-18)	D	P	R(3)	Q(1)
b. Steam Generator Blowdown Tank (RM-23)	D	M	R(3)	Q(1)
2. Flow Rate Measurement Devices				
a. Liquid Radwaste Effluent Line (FR-20)	D(4)	N.A.	R	Q
b. Steam Generator Blowdown Effluent Line (FR-53)	D(4)	N.A.	R	Q
c. Oily Water Separator Effluent Line (FR-251)	Daily(4)	N.A.	R	Q
3. Radioactivity Monitor Not Providing Automatic Termination of Release				
Oily Water Separator Effluent Line (RM-3)	D	M	R(3)	Q(2)

TITLE: Radioactive Effluent Controls Program

APPENDIX 6.1 (Continued)

TABLE 6.1.1-2
TABLE NOTATION

- (1) The CHANNEL FUNCTIONAL TEST shall also demonstrate that automatic isolation of this pathway and Control Room alarm annunciation occurs if any of the following conditions exists:
 - a. Instrument indicates measured levels above the Alarm/Trip Setpoint (isolation and alarm), or
 - b. Relay control circuit failure (isolation only), or
 - c. Instrument indicates a downscale failure (alarm only), or
 - d. Instrument controls not set in operate mode (alarm only).
- (2) The CHANNEL FUNCTIONAL TEST shall also demonstrate that Control Room alarm annunciation occurs if any of the following conditions exist:
 - a. Instrument indicates measured levels above the Alarm Setpoint, or
 - b. Circuit failure, or
 - c. Instrument indicates a downscale failure, or
 - d. Instrument controls not set in operate mode.
- (3) The initial CHANNEL CALIBRATION shall be performed using one or more of the reference standards certified by the National Bureau of Standards (NBS) or using standards that have been obtained from suppliers that participate in measurement assurance activities with NBS. These standards shall permit calibrating the system over its intended range of energy and measurement range. For subsequent CHANNEL CALIBRATION, sources that have been related to the initial calibration shall be used.
- (4) CHANNEL CHECK shall consist of verifying indication of flow during periods of release. CHANNEL CHECK for FR-251 shall be made once per calendar day*, and for FR-20 and FR-53 shall be made at least once per 24 hours on days on which continuous, periodic, or batch releases are made.

(5) Frequency Notation

<u>Notation</u>	<u>Frequency</u>
D	At least once per 24 hours
Daily	At least once per calendar day*
M	At least once per 31 days
Q	At least once per 92 days
R	At least once per 18 months
P	Completed prior to each release
N.A.	Not Applicable

* The frequency "once per calendar day" could result in two successive channel checks nearly 48 hours apart over a two day period. This frequency is different from and should not be confused with the frequency notation "D" (at least once per 24 hours) defined in Technical Specifications.

TITLE: Radioactive Effluent Controls Program

APPENDIX 6.1 (Continued)

6.1.2 Radioactive Gaseous Effluent Monitoring Instrumentation (Also covered by ECG 39.4)

Commitment for Operation

6.1.2.1 The radioactive gaseous effluent monitoring instrumentation channels shown in Table 6.1.2-1 shall be OPERABLE with their Alarm/Trip Setpoints set to ensure that the limits of Commitment 6.1.6.1 is not exceeded. The Alarm/Trip Setpoints of these channels meeting Commitment 6.1.6.1 shall be determined and adjusted in accordance with the methodology and parameters in the ODCP.

Applicability: As shown in Table 6.1.2-1.

Action:

- a. With a radioactive gaseous effluent monitoring instrumentation channel Alarm/Trip Setpoint less conservative than required by the above Commitment, immediately suspend the release of radioactive gaseous effluents monitored by the affected channel, or declare the channel inoperable.
- b. With the number of OPERABLE radioactive gaseous effluent monitoring instrumentation channels less than the Minimum Channels OPERABLE, take the ACTION shown in Table 6.1.2-1. Restore the inoperable instrumentation to OPERABLE status within the time specified in the ACTION or explain in the next Annual Radioactive Effluent Release Report why this inoperability was not corrected within the time specified.

Surveillance Requirements

6.1.2.2 Each radioactive gaseous effluent monitoring instrumentation channel shall be demonstrated OPERABLE by performance of the CHANNEL CHECK, SOURCE CHECK, CHANNEL CALIBRATION and CHANNEL FUNCTIONAL TEST at the frequencies shown in Table 6.1.2-2.

TITLE: Radioactive Effluent Controls Program

APPENDIX 6.1 (Continued)

TABLE 6.1.2-1

RADIOACTIVE GASEOUS EFFLUENT MONITORING INSTRUMENTATION

<u>Instrument</u>	<u>Minimum Channel Operable</u>	<u>Applicability</u>	<u>Action</u>
1. Gaseous Radwaste System			
Noble Gas Activity Monitor - Providing Alarm and Automatic Termination of Release (RM-22)	1	*	5
2. Plant Vent system			
a. Noble Gas Activity Monitor Providing Alarm (RM-14 or RM-14R)	1	*	7
b. Iodine Sampler	1	*	9
c. Particulate Sampler	1	*	9
d. Flow Rate Monitor (FR-12)	1	*	6
e. Iodine Sampler Flow Rate Monitor	1	*	6
3. Containment Purge System			
Noble Gas Activity Monitor - Providing Alarm and Automatic Termination of Release (RM-44A or 44B)	2 ⁽¹⁾	**	8

⁽¹⁾ 2 channels required in Modes 1, 2, 3 and 4. Only 1 channel required in Mode 6 during Core Alterations or movement of irradiated fuel within containment.

TITLE: Radioactive Effluent Controls Program

APPENDIX 6.1 (Continued)

TABLE 6.1.2-1 (Continued)

TABLE NOTATIONS

*At all times.

** MODES 1-4; also MODE 6 during CORE ALTERATIONS or movement of irradiated fuel within containment.

ACTION 5 With the number of channels OPERABLE less than required by the Minimum Channels OPERABLE requirement, the contents of the tank(s) may be released to the environment for up to 14 days provided that prior to initiating the release:

- a. At least two independent samples of the tank's contents are analyzed, and
- b. At least two technically qualified members of the facility staff independently verify the release rate calculations and discharge valve lineup.

Otherwise, suspend release of radioactive effluents via this pathway.

ACTION 6 With the number of channels OPERABLE less than required by the Minimum Channels OPERABLE requirement, effluent releases via this pathway may continue for up to 30 days provided the flow rate is estimated at least once per 4 hours.

ACTION 7 With the number of channels OPERABLE less than required by the Minimum Channels OPERABLE requirement, effluent releases via this pathway may continue for up to 30 days provided grab samples are taken at least once per 12 hours and these samples are analyzed for radioactivity within 24 hours.

ACTION 8 With the number of channels OPERABLE less than required by the Minimum Channels OPERABLE requirement, immediately suspend containment PURGING of radioactive effluents via this pathway.

ACTION 9 With the number of channels OPERABLE less than required by the Minimum Channels OPERABLE requirement, effluent releases via the affected pathway may continue for up to 30 days provided samples are continuously collected with auxiliary sampling equipment as required in Commitment Table 6.1.6-1.

NOTE FOR ACTION 9: To respond to the low flow alarm, determine that a simple fix cannot be made and that an auxiliary sampler is needed. Move the sampler in, hook up and verify operation, a maximum of two hours is considered a reasonable time. Over two hours should be considered as exceeding the time limitation of the commitment for operation (ECG 39.4).

TITLE: Radioactive Effluent Controls Program

APPENDIX 6.1 (Continued)

TABLE 6.1.2-2
RADIOACTIVE GASEOUS EFFLUENT MONITORING INSTRUMENTATION SURVEILLANCE
REQUIREMENTS

<u>Instrument</u>	<u>Channel Check</u>	<u>Source Check</u>	<u>Channel Calibration</u>	<u>Channel Functional Test</u>	<u>Modes for Which Surveillance Is Required</u>
1. Gaseous Radwaste System					
Noble Gas Activity Monitor - Providing					
Alarm and Automatic Termination of Release (RM-22)	P	P	R(3)	Q(1)	*
2. Plant Vent System					
a. Noble Gas Activity Monitor Providing Alarm (RM-14 or RM-14R)					
	D	M	R(3)	Q(2)	*
b. Iodine Sampler					
	W(4)	N.A.	N.A.	N.A.	*
c. Particulate Sampler					
	W(4)	N.A.	N.A.	N.A.	*
d. Flow Rate Monitor (FR-12)					
	D	N.A.	R	Q	*
e. Iodine Sampler Flow Rate Monitor					
	D	N.A.	R	Q	*
3. Containment Purge System					
Noble Gas Activity Monitor - Providing Alarm and Automatic Termination of Release (RM-44A or 44B)					
	D	P	R(3)	Q(1)	**

TITLE: Radioactive Effluent Controls Program

APPENDIX 6.1 (Continued)

TABLE 6.1.2-2 (Continued)

TABLE NOTATIONS

* At all times.

** MODES 1-4; also MODE 6 during CORE ALTERATIONS or movement of irradiated fuel within containment.

- (1) The CHANNEL FUNCTIONAL TEST shall also demonstrate that automatic isolation of this pathway and control room alarm annunciation occurs if any of the following conditions exists:
 - a. Instrument indicates measured levels above the Alarm/Trip Setpoint (isolation and alarm), or
 - b. Instrument indicates a downscale failure (alarm only), or
 - c. Instrument controls not set in operate mode (alarm only).
- (2) The CHANNEL FUNCTIONAL TEST shall also demonstrate that control room alarm annunciation occurs if any of the following conditions exist:
 - a. Instrument indicates measured levels above the Alarm Setpoint, or
 - b. Circuit failure, or
 - c. Instrument indicates a downscale failure, or
 - d. Instrument controls not set in operate mode.
- (3) The initial CHANNEL CALIBRATION shall be performed using one or more of the reference standards certified by the National Bureau of Standards (NBS) or using standards that have been obtained from suppliers that participate in measurement assurance activities with NBS. These standards shall permit calibrating the system over its intended range of energy and measurement range. For subsequent CHANNEL CALIBRATION, sources that have been related to the initial calibration shall be used.
- (4) The CHANNEL CHECK shall consist of verifying that the iodine cartridge and particulate filter are installed in the sample holders.

(5) Frequency Notation

<u>Notation</u>	<u>Frequency</u>
D	At least once per 24 hours
W	At least once per 7 days
M	At least once per 31 days
Q	At least once per 92 days
R	At least once per 18 months
P	Completed prior to each release
N.A.	Not Applicable

**PACIFIC GAS AND ELECTRIC COMPANY
INTER-DEPARTMENTAL ADMINISTRATIVE PROCEDURE**

**NUMBER CY2.ID1
REVISION 6A
PAGE 18 OF 39**

TITLE: Radioactive Effluent Controls Program

APPENDIX 6.1 (Continued)

6.1.3 Liquid Effluents - CONCENTRATION

Commitment for Operation

- 6.1.3.1 The concentration of radioactive material released in liquid effluents to UNRESTRICTED AREAS (see TS Figure 5.1-3) shall be limited to the concentrations specified in 10 CFR Part 20, Appendix B, Table 2, Column 2 for radionuclides other than dissolved or entrained noble gases. For dissolved or entrained noble gases, the concentration shall be limited to 2×10^{-4} microcurie/ml total activity.

Applicability: At all times.

Action:

With the concentration of radioactive material released in liquid effluents to UNRESTRICTED AREAS exceeding the above limits, immediately restore the concentration to within the above limits.

Surveillance Requirements

- 6.1.3.2 Radioactive liquid wastes shall be sampled and analyzed according to the sampling and analysis program of Table 6.1.3-1.
- 6.1.3.3 The results of the radioactivity analyses shall be used in accordance with the methodology and parameters in the ODCP to assure that the concentrations at the point of release are maintained within the limits of Commitment 6.1.3.1.

TITLE: Radioactive Effluent Controls Program

APPENDIX 6.1 (Continued)

TABLE 6.1.3-1
 RADIOACTIVE LIQUID WASTE SAMPLING AND ANALYSIS PROGRAM

LIQUID RELEASE TYPE	SAMPLING FREQUENCY	MINIMUM ANALYSIS FREQUENCY	TYPE OF ACTIVITY ANALYSIS	LOWER LIMIT OF DETECTION (LLD) ($\mu\text{Ci/ml}$) ⁽¹⁾
1. Batch Waste Release Tanks ⁽⁴⁾	P Each Batch	P Each Batch	Principal Gamma Emitters ⁽⁶⁾	5×10^{-7}
			I-131	1×10^{-6}
	P One Batch/M	M	Dissolved and Entrained Gases (Gamma emitters)	1×10^{-5}
	P Each Batch	M Composite ⁽²⁾	H-3	1×10^{-5}
			Gross Alpha	1×10^{-7}
	P Each Batch	Q Composite ⁽²⁾	Sr-89, Sr-90	5×10^{-8}
			Fe-55	1×10^{-6}
2. Continuous Releases ⁽⁵⁾ Steam Generator Blowdown Tank	D Grab Sample	W Composite ⁽³⁾	Principal Gamma Emitters ⁽⁶⁾	5×10^{-7}
			I-131	1×10^{-6}
	M Grab Sample	M	Dissolved and Entrained Gases (Gamma emitters)	1×10^{-5}
	D Grab Sample	M Composite ⁽³⁾	H-3	1×10^{-5}
			Gross Alpha	1×10^{-7}
	D Grab Sample	Q Composite ⁽³⁾	Sr-89, Sr-90	5×10^{-8}
			Fe-55	1×10^{-6}
3. Continuous Releases ⁽⁵⁾ Oily Water Separator Effluent	D Grab Sample	W Composite ⁽³⁾	Principal Gamma Emitters ⁽⁶⁾	5×10^{-7}

TITLE: Radioactive Effluent Controls Program

APPENDIX 6.1 (Continued)

TABLE 6.1.3-1 (Continued)

TABLE NOTATIONS

- (1) The LLD is defined, for the purposes of these specifications, as the smallest concentration of radioactive material in a sample that will yield a net count, above system background, that will be detected with 95% probability with only 5% probability of falsely concluding that a blank observation represents a "real" signal.

For a particular measurement system, which may include radiochemical separation:

$$LLD = \frac{4.66s_b}{E * V * 2.22 \times 10^6 * Y * \exp(-\lambda\Delta t)}$$

Where:

- LLD = the "a priori" lower limit of detection (microcuries per unit mass or volume),
- s_b = the standard deviation of the background counting rate or of the counting rate of a blank sample as appropriate (counts per minute),
- E = the counting efficiency (counts per disintegration),
- V = the sample size (units of mass or volume),
- 2.22×10^6 = the number of disintegrations per minute per microcurie,
- Y = the fractional radiochemical yield, when applicable,
- λ = the radioactive decay constant for the particular radionuclide (sec^{-1}), and
- Δt = the elapsed time between the midpoint of sample collection and the time of counting (sec).

Typical values of E, V, Y, and Δt should be used in the calculation.

It should be recognized that the LLD is defined as an a priori (before the fact) limit representing the capability of a measurement system and not as an a posteriori (after the fact) limit for a particular measurement.

- (2) A composite sample is one in which the quantity of liquid sampled is proportional to the quantity of liquid waste discharged and in which the method of sampling employed results in a specimen which is representative of the liquids released.
- (3) To be representative of the quantities and concentrations of radioactive materials in liquid effluents, samples shall be composited in proportion to the rate of flow of the effluent stream. Prior to analyses, all samples taken for the composite shall be thoroughly mixed in order for the composite sample to be representative of the effluent release.
- (4) A batch release is the discharge of liquid wastes of a discrete volume. Prior to sampling for analyses, each batch shall be isolated, and then thoroughly mixed, by a method described in the ODCP, to assure representative sampling.

TITLE: Radioactive Effluent Controls Program

APPENDIX 6.1 (Continued)

TABLE 6.1.3-1 (Continued)

TABLE NOTATIONS

- (5) A continuous release is the discharge of liquid wastes of a nondiscrete volume; e.g., from a volume of system that has an input flow during the continuous release.
- (6) The principal gamma emitters for which the LLD specification applies include the following radionuclides: Mn-54, Fe-59, Co-58, Co-60, Zn-65, Mo-99, Cs-134, Cs-137, and Ce-141. Ce-144 shall also be measured but with an LLD of 5×10^{-6} . This list does not mean that only these nuclides are to be considered. Other gamma peaks that are identifiable, together with those of the above nuclides, shall also be analyzed and reported in the Annual Radioactive Effluent Release Report.
- (7) Frequency Notation:

<u>Notation</u>	<u>Frequency</u>
D	At least once per 24 hours.
W	At least once per 7 days.
M	At least once per 31 days.
Q	At least once per 92 days.
P	Completed prior to each release.

6.1.4 Liquid Effluents - Dose

Commitment for Operation

6.1.4.1 The dose or dose commitment to a MEMBER OF THE PUBLIC from radioactive materials in liquid effluents released, from each unit, to UNRESTRICTED AREAS (see FSAR Figure 5.1-3) shall be limited:

- a. During any calendar quarter to less than or equal to 1.5 mrem to the whole body and to less than or equal to 5 mrem to any organ, and
- b. During any calendar year to less than or equal to 3 mrem to the whole body and to less than or equal to 10 mrem to any organ.

Applicability: At all times.

Action:

- a. With the calculated dose from the release of radioactive materials in liquid effluents exceeding any of the above limits, prepare and submit to the Commission within 30 days, pursuant to 10 CFR 50.4, a Special Report that identifies the cause(s) for exceeding the limit(s) and defines the corrective actions that have been taken to reduce the releases and the proposed corrective actions to be taken to assure that subsequent releases will be in compliance with the above limits.

TITLE: Radioactive Effluent Controls Program

APPENDIX 6.1 (Continued)

Surveillance Requirements

6.1.4.2 Cumulative dose contributions from liquid effluents for the current calendar quarter and the current calendar year shall be determined in accordance with the methodology and parameters in the ODCP at least once per 31 days.

6.1.5 Liquid Radwaste Treatment System

Commitment for Operation

6.1.5.1 The Liquid Radwaste Treatment System* shall be OPERABLE and appropriate portions of the system shall be used to reduce the radioactive materials in liquid wastes prior to their discharge when the projected doses due to the liquid effluent, from each unit, to UNRESTRICTED AREAS (see FSAR Figure 2.1-2) would exceed 0.06 mrem to the whole body or 0.2 mrem to any organ in a 31-day period.

Applicability: At all times.

Action:

- a. With any portion of the Liquid Radwaste Treatment System not in operation and with radioactive liquid waste being discharged without treatment and in excess of the above limits, prepare and submit to the Commission within 30 days, pursuant to 10 CFR 50.4, a Special Report which includes the following information:
1. Explanation of why liquid radwaste was being discharged without treatment, identification of any inoperable equipment or subsystems, and the reason for the inoperability,
 2. Action(s) taken to restore the inoperable equipment to OPERABLE status, and
 3. Summary description of action(s) taken to prevent a recurrence.

Surveillance Requirements

6.1.5.2 Doses due to liquid releases from each unit to UNRESTRICTED AREAS shall be projected at least once per 31 days, in accordance with the methodology and parameters in the ODCP when Liquid Radwaste Treatment Systems are not being fully utilized.

6.1.5.3 The installed Liquid Radwaste Treatment System shall be considered OPERABLE by meeting Commitments 6.1.3.1 and 6.1.4.1.

* The Liquid Radwaste Treatment System is common to both units.

TITLE: Radioactive Effluent Controls Program

APPENDIX 6.1 (Continued)

6.1.6 Gaseous Effluents - Dose Rate

Commitment for Operation

6.1.6.1 The dose rate due to radioactive materials released in gaseous effluents from the site to areas at or beyond the SITE BOUNDARY (see FSAR Figure 2.1-2) shall be limited to the following:

- a. For noble gases: Less than or equal to 500 mrem/yr to the whole body and less than or equal to 3000 mrem/yr to the skin, and
- b. For Iodine-131, for Iodine-133, for tritium, and for all radionuclides in particulate form with half-lives greater than 8 days: Less than or equal to 1500 mrem/yr to any organ.

Applicability: At all times.

Action:

With the dose rate(s) exceeding the above limits, immediately decrease the release rate to within the above limit(s).

Surveillance Requirements

- 6.1.6.2 The dose rate due to noble gases in gaseous effluents shall be determined to be within the above limits in accordance with the methodology and procedures of the ODCP.
- 6.1.6.3 The dose rate due to Iodine-131, Iodine-133, tritium, and all radionuclides in particulate form with half-lives greater than 8 days in gaseous effluents shall be determined to be within the above limits in accordance with the methodology and procedures of the ODCP by obtaining representative samples and performing analyses in accordance with the sampling and analysis program specified in Table 6.1.6-1.

TITLE: Radioactive Effluent Controls Program

APPENDIX 6.1 (Continued)

TABLE 6.1.6-1

RADIOACTIVE GASEOUS WASTE SAMPLING AND ANALYSIS PROGRAM

GASEOUS RELEASE TYPE	SAMPLING FREQUENCY	MINIMUM ANALYSIS FREQUENCY	TYPE OF ACTIVITY ANALYSIS	LOWER LIMIT OF DETECTION (LLD) ($\mu\text{Ci/ml}$) ⁽¹⁾
1. Waste Gas Decay Tank	P Each Tank Grab Sample	P Each Tank	Principal Gamma Emitters ⁽⁷⁾ (noble gases)	1×10^{-4}
2. Containment Purge	P Each Purge ⁽²⁾ Grab Sample	P Each Purge ⁽²⁾	Principal Gamma Emitters ⁽⁷⁾ (noble gases)	1×10^{-4}
			I-131, I-133	1×10^{-9}
			Principal Gamma Emitters (particulates)	1×10^{-9}
			H-3	1×10^{-6}
3. Plant Vent	M ⁽²⁾ Grab Sample	M ⁽²⁾	Principal Gamma Emitters ⁽⁷⁾ (noble gases)	1×10^{-4}
	W ^{(3) (5)} Grab Sample	W	H-3	1×10^{-6}
4. All Release Types as listed in 1., 2., 3., above, at the plant vent	Continuous ⁽⁶⁾	W ⁽⁴⁾	I-131	1×10^{-12}
			Charcoal Sample	I-133
	Continuous ⁽⁶⁾	W ⁽⁴⁾ Particulate Sample	Principal Gamma Emitters ⁽⁷⁾	1×10^{-11}
	Continuous ⁽⁶⁾	M Composite Particulate Sample	Gross Alpha	1×10^{-11}
	Continuous ⁽⁶⁾	Q Composite Particulate Sample	Sr-89, Sr-90	1×10^{-11}
5. Steam Generator Blowdown Tank Vent	M ⁽⁸⁾	M ⁽⁸⁾	Principal Gamma Emitters ⁽⁷⁾ (noble gases)	1×10^{-4}

TITLE: Radioactive Effluent Controls Program

APPENDIX 6.1 (Continued)

TABLE 6.1.6-1 (Continued)

TABLE NOTATIONS

- (1) The LLD is defined, for purposes of these specifications, as the smallest concentration of radioactive material in a sample that will yield a net count, above system background, that will be detected with 95% probability with only 5% probability of falsely concluding that a blank observation represents a "real" signal.

For a particular measurement system, which may include radiochemical separation:

$$LLD = \frac{4.66s_b}{E * V * 2.22 \times 10^6 * Y * \exp(-\lambda\Delta t)}$$

Where:

- LLD = the "a priori" lower limit of detection (microcuries per unit mass or volume),
s_b = the standard deviation of the background counting rate or of the counting rate of a blank sample as appropriate (counts per minute),
E = the counting efficiency (counts per disintegration),
V = the sample size (units of mass or volume),
2.22 x 10⁶ = the number of disintegrations per minute per microcurie,
Y = the fractional radiochemical yield, when applicable,
λ = the radioactive decay constant for the particular radionuclide (sec⁻¹), and
Δt = the elapsed time between the midpoint of sample collection and the time of counting (sec).

Typical values of E, V, Y, and Δt should be used in the calculation.

It should be recognized that the LLD is defined as an a priori (before the fact) limit representing the capability of a measurement system and not as an a posteriori (after the fact) limit for a particular measurement.

- (2) Sampling and analyses shall also be performed following shutdown, startup, or a THERMAL POWER change exceeding 15% of the RATED THERMAL POWER within a 1-hour period.
- (3) Tritium grab samples shall be taken a least once per 24 hours when the refueling canal is flooded.

TITLE: Radioactive Effluent Controls Program

APPENDIX 6.1 (Continued)

TABLE 6.1.6-1 (Continued)

TABLE NOTATIONS (Continued)

- (4) Samples shall be changed at least once per 7 days and analyses shall be completed within 48 hours after changing or after removal from sampler. Sampling shall also be performed at least once per 24 hours for at least 7 days following each shutdown, startup or THERMAL POWER change exceeding 15% of RATED THERMAL POWER within a 1-hour period and analyses shall be completed within 48 hours of changing. When samples collected for 24 hours are analyzed, the corresponding LLD's may be increased by a factor of 10. This requirement does not apply if: (1) analysis shows that the DOSE EQUIVALENT I-131 concentration in the reactor coolant has not increased more than a factor of 3; and (2) the noble gas monitor shows that effluent activity has not increased more than a factor of 3.
- (5) Tritium grab samples shall be taken at least once per 7 days from the ventilation exhaust from the spent fuel pool area, whenever spent fuel is in the spent fuel pool.
- (6) The ratio of the sample flow rate to the sampled stream flow rate shall be known for the time period covered by each dose or dose rate calculation made in accordance with Commitments 6.1.6.1, 6.1.7.1, and 6.1.8.1.
- (7) The principal gamma emitters for which the LLD specification applies include the following radionuclides: Kr-87, Kr-88, Xe-133, Xe-133m, Xe-135, and Xe-138 in noble gas releases and Mn-54, Fe-59, Co-58, Co-60, Zn-65, Mo-99, I-131, Cs-134, Cs-137, Ce-141, and Ce-144 in Iodine and particulate releases. This list does not mean that only these nuclides are to be considered. Other gamma peaks that are identifiable, together with those of the above nuclides, shall also be analyzed and reported in the Annual Radioactive Effluent Release Report.
- (8) Grab samples shall be taken and analyzed at least once per 31 days whenever there is flow through the steam generator blowdown tank. Releases of radioiodines shall be estimated based on secondary coolant concentration and partitioning factors during releases or shall be measured.

(9) Frequency Notation

<u>Notation</u>	<u>Frequency</u>
W	At least once per 7 days
M	At least once per 31 days
Q	At least once per 92 days
P	Completed prior to each release

TITLE: Radioactive Effluent Controls Program

APPENDIX 6.1 (Continued)

6.1.7 Dose - Noble Gases

Commitment for Operation

6.1.7.1 The air dose due to noble gases released in gaseous effluents, from each unit, to areas at or beyond the SITE BOUNDARY (see TS Figure 5.1-3) shall be limited to the following:

- a. During any calendar quarter: Less than or equal to 5 mrad for gamma radiation and less than or equal to 10 mrad for beta radiation, and
- b. During any calendar year: Less than or equal to 10 mrad for gamma radiation and less than or equal to 20 mrad for beta radiation.

Applicability: At all times.

Action:

- a. With the calculated air dose from radioactive noble gases in gaseous effluents exceeding any of the above limits, prepare and submit to the Commission within 30 days, pursuant to 10 CFR 50.4, a Special Report that identifies the cause(s) for exceeding the limit(s), defines the corrective actions that have been taken to reduce the releases and the proposed corrective actions to be taken to assure that subsequent releases will be in compliance with the above limits.

Surveillance Requirements

6.1.7.2 Cumulative dose contributions for the current calendar quarter and current calendar year for noble gases shall be determined in accordance with the methodology and parameters in the ODCP at least once per 31 days.

6.1.8 Dose - Iodine-131, Iodine-133, Tritium, and Radioactive Material in Particulate Form

Commitment for Operation

6.1.8.1 The dose to a MEMBER OF THE PUBLIC from Iodine-131, Iodine-133, tritium and all radionuclides in particulate form with half-lives greater than 8 days in gaseous effluents released, from each unit, to areas at and beyond the SITE BOUNDARY (see TS Figure 5.1-3) shall be limited to the following:

- a. During any calendar quarter: Less than or equal to 7.5 mrem to any organ and,
- b. During any calendar year: Less than or equal to 15 mrem to any organ.

Applicability: At all times.

TITLE: Radioactive Effluent Controls Program

APPENDIX 6.1 (Continued)

Action:

- a. With the calculated dose from the release of Iodine-131, Iodine-133, tritium, and radionuclides in particulate form with half-lives greater than 8 days, in gaseous effluents exceeding any of the above limits, prepare and submit to the Commission within 30 days, pursuant to 10 CFR 50.4, a Special Report that identifies the cause(s) for exceeding the limit(s), defines the corrective actions that have been taken to reduce the releases and the proposed actions to be taken to assure that subsequent releases will be in compliance with the above limits.

Surveillance Requirements

- 6.1.8.2 Cumulative dose contributions for the current calendar quarter and current calendar year for Iodine-131, Iodine-133, tritium, and radionuclides in particulate form with half-lives greater than 8 days shall be determined in accordance with the methodology and parameters in the ODCP at least once per 31 days.

6.1.9 Gaseous Radwaste Treatment System

Commitment for Operation

- 6.1.9.1 The GASEOUS RADWASTE SYSTEM and the VENTILATION EXHAUST TREATMENT SYSTEM shall be OPERABLE. The appropriate portions of these systems shall be used to reduce releases of radioactivity when the projected doses in 31 days due to gaseous effluent releases, from each unit, to areas at and beyond the SITE BOUNDARY (see FSAR Figure 2.1-2), would exceed 0.2 mrad to air from gamma radiation or 0.4 mrad to air from beta radiation or 0.3 mrem to any organ of a MEMBER OF THE PUBLIC.

Applicability: At all times.

Action:

- a. With radioactive gaseous waste being discharged without treatment and in excess of the above limits, prepare and submit to the Commission within 30 days, pursuant to 10 CFR 50.4, a Special Report that includes the following information:
1. Identification of the inoperable equipment or subsystems and the reason for inoperability.
 2. Action(s) taken to restore the inoperable equipment to OPERABLE status, and
 3. Summary description of action(s) taken to prevent a recurrence.

TITLE: Radioactive Effluent Controls Program

APPENDIX 6.1 (Continued)

Surveillance Requirements

- 6.1.9.2 Doses due to gaseous releases from each unit to areas at and beyond the SITE BOUNDARY shall be projected at least once per 31 days, in accordance with the methodology and parameters in the ODCP when Gaseous Radwaste Treatment Systems are not being fully utilized.
- 6.1.9.3 The installed VENTILATION EXHAUST TREATMENT SYSTEM and GASEOUS RADWASTE SYSTEM shall be considered OPERABLE by meeting Commitments 6.1.6.1 and 6.1.7.1 or 6.1.8.1.

6.1.10 Total Dose

Commitment for Operation

- 6.1.10.1 The annual (calendar year) dose or dose commitment to any MEMBER OF THE PUBLIC due to releases of radioactivity and to radiation from uranium fuel cycle sources shall be limited to less than or equal to 25 mremS to the whole body or any organ, except the thyroid, which shall be limited to less than or equal to 75 mremS.

Applicability: At all times.

Action:

- a. With the calculated doses from the release of radioactive materials in liquid or gaseous effluents exceeding twice the limits of Commitments 6.1.4.1.a, 6.1.4.1.b, 6.1.7.1.a, 6.1.7.1.b, 6.1.8.1.a, or 6.1.8.1.b, calculations shall be made including direct radiation contributions from the units and from outside storage tanks to determine whether the above limits of Regulatory Commitment 6.1.10.1 have been exceeded. If such is the case, prepare and submit to the Commission within 30 days, pursuant to 10 CFR 50.4, a Special Report that defines the corrective action to be taken to reduce subsequent releases to prevent recurrence of exceeding the above limits and includes the schedule for achieving conformance with the above limits. This Special Report, as defined in 10 CFR 20.2203(a), shall include an analysis that estimates the radiation exposure (dose) to a MEMBER OF THE PUBLIC from uranium fuel cycle sources, including all effluent pathway and direct radiation, for the calendar year that includes the release(s) covered by this report. It shall also describe levels of radiation and concentrations of radioactive material involved, and the cause of the exposure levels or concentrations. If the estimated dose(s) exceeds the above limits, and if the release condition resulting in violation of 40 CFR Part 190 has not already been corrected, the Special Report shall include a request for a variance in accordance with the provisions of 40 CFR Part 190. Submittal of the report is considered a timely request, and a variance is granted until staff action on the request is complete.

TITLE: Radioactive Effluent Controls Program

APPENDIX 6.1 (Continued)

Surveillance Requirements

6.1.10.2 Cumulative dose contributions from liquid and gaseous effluents shall be determined in accordance with Commitments 6.1.4.2, 6.1.7.2, and 6.1.8.2, and in accordance with the methodology and parameters in the ODCP.

6.1.10.3 Cumulative dose contributions from direct radiation from the units and from outside storage tanks shall be determined in accordance with the methodology and parameters in the ODCP. This requirement is applicable only under conditions set forth in ACTION a. of Commitment 6.1.10.1.

6.1.11 Radiological Environmental Monitoring

6.1.11.1 Commitment for Operation - The Radiological Environmental Monitoring Program shall be conducted as specified in RP1.ID11, "Environmental Radiological Monitoring Procedure."

Applicability: At all times.

Action:

- a. With the confirmed level of radioactivity as the result of plant effluents in an environmental sampling medium at a specified location exceeding the "Reporting Levels for Nonroutine Operating Reports" in RP1.ID11 when averaged over any calendar quarter, prepare and submit to the Commission within 30 days from the end of the quarter, pursuant to 10 CFR 50.4, a Nonroutine Radiological Environmental Operating Report that identifies the cause(s) for exceeding the limit(s) and defines the corrective actions to be taken to reduce radioactive effluents so that the potential annual dose to a MEMBER OF THE PUBLIC is less than the calendar year limits of Commitment 6.1.4.1, 6.1.7.1, or 6.1.8.1. A confirmatory reanalysis of the original, a duplicate, or a new sample may be desirable, as appropriate. The results of the confirmatory analysis shall be completed at the earliest time consistent with the analysis, but in any case within 30 days. When more than one of the radionuclides from "Reporting Levels for Nonroutine Operating Reports" in RP1.ID11 are detected in the sampling medium, this report shall be submitted if:

$$\frac{\text{concentration}(1)}{\text{reportinglevel}(1)} + \frac{\text{concentration}(2)}{\text{reportinglevel}(2)} + \dots \geq 1.0$$

TITLE: Radioactive Effluent Controls Program

APPENDIX 6.1 (Continued)

When radionuclides other than those in the "Reporting Levels for Nonroutine Operating Reports" in RP1.ID11 are detected and are the result of plant effluents, a Nonroutine Radiological Environmental Operating Report shall be submitted if the potential annual dose to a MEMBER OF THE PUBLIC from all radionuclides is equal to or greater than the calendar year limits of Commitment 6.1.4.1, 6.1.7.1, or 6.1.8.1. This report shall include an evaluation of any release conditions, environmental factors, or other aspects necessary to explain the anomalous result.

6.1.12 LAND USE CENSUS

6.1.12.1 A Land Use Census shall be conducted as specified in RP1.ID11, "Environmental Radiological Monitoring Procedure."

Applicability: At all times.

Action:

- a. With a Land Use Census identifying a location(s) that yields a calculated dose or dose commitment greater than the values currently being calculated in Commitment 6.1.8.2, identify the new location(s) in the next Annual Radioactive Effluent Release Report.
- b. With a Land Use Census identifying a location(s) that yields a calculated dose or dose commitment (via the same exposure pathway) 20% greater than at a location from which samples are currently being obtained in accordance with Commitment 6.1.11.1, add the new location(s) within 30 days to the Radiological Environmental Monitoring Program given in the ERMP. The sampling location(s), excluding the control station location, having the lowest calculated dose or dose commitment(s), via the same exposure pathway, may be deleted from this monitoring program after October 31 of the year in which this Land Use Census was conducted. Submit in the next Annual Radioactive Effluent Release Report documentation for a change in the ERMP including a revised figure(s) and table(s) for the ERMP reflecting the new location(s) with information supporting the change in sampling locations.

Bases

6.1.1 Radioactive Liquid Effluent Monitoring Instrumentation

The radioactive liquid effluent instrumentation is provided to monitor and control, as applicable, the releases of radioactive materials in liquid effluents during actual or potential releases of liquid effluents. The Alarm/Trip Setpoints for these instruments shall be calculated and adjusted in accordance with the methodology and parameters in the ODCP to ensure that the alarm/trip will occur prior to exceeding the limits of 10 CFR Part 20. The OPERABILITY and use of this instrumentation is consistent with the requirements of General Design Criteria 60, 63, and 64 of Appendix A to 10 CFR Part 50.

TITLE: Radioactive Effluent Controls Program

APPENDIX 6.1 (Continued)

6.1.2 Radioactive Gaseous Effluent Monitoring Instrumentation

The radioactive gaseous effluent instrumentation is provided to monitor and control, as applicable, the releases of radioactive materials in gaseous effluents during actual or potential releases of gaseous effluents. The Alarm/Trip Setpoints for these instruments shall be calculated and adjusted in accordance with the methodology and parameters in the ODCP to ensure that the alarm/trip will occur prior to exceeding the limits of NUREG 0133. The OPERABILITY and use of this instrumentation is consistent with the requirements of General Design Criteria 60, 63, and 64 of Appendix A to 10 CFR Part 50. The sensitivity of any noble gas activity monitors used to show compliance with the gaseous effluent release requirements of Regulatory Commitment 6.1.7.1 shall be such that concentrations as low as 1×10^{-5} $\mu\text{Ci/ml}$ are measurable.

6.1.3 Liquid Effluents - Concentration

This Regulatory Commitment is provided to ensure that the concentration of radioactive materials released in liquid waste effluents to UNRESTRICTED AREAS will be less than the concentration levels specified in 10 CFR Part 20, Appendix B, Table 2, Column 2. This limitation provides additional assurance that the levels of radioactive materials in bodies of water in UNRESTRICTED AREAS will result in exposures within: (1) the Section II.A design objectives of Appendix I, 10 CFR Part 50, to a MEMBER OF THE PUBLIC, and (2) the limits of 10 CFR 20.1301(e) to the population. The concentration limit for dissolved or entrained noble gases is based upon the assumption that Xe-135 is the controlling radioisotope and its Effluent Concentration Limit (ECL) in air (submersion) was converted to an equivalent concentration in water using the methods described in International Commission on Radiological Protection (ICRP) Publication 2.

This Regulatory Commitment applies to the release of radioactive materials in liquid effluents from all units at the site.

The required detection capabilities for radioactive materials in liquid waste samples are tabulated in terms of the lower limits of detection (LLDs). Detailed discussion of the LLD, and other detection limits can be found in Currie, L.A., "Lower Limit of Detection: Definition and Elaboration of a Proposed Position for Radiological Effluent and Environmental Measurements," NUREG/CR-4007 (September 1984), and in the HASL Procedures Manual, HASL-300 (revised annually).

TITLE: Radioactive Effluent Controls Program

APPENDIX 6.1 (Continued)

6.1.4 Liquid Effluents - Dose

This Regulatory Commitment is provided to implement the requirements of Sections II.A, III.A and IV.A of Appendix I, 10 CFR Part 50. The Limiting Condition for Operation implements the guides set forth in Section II.A of Appendix I. The ACTION statements provide the required operating flexibility and at the same time implement the guides set forth in Section IV.A of Appendix I to assure that the releases of radioactive material in liquid effluents to UNRESTRICTED AREAS will be kept "as low as is reasonably achievable." The dose calculation methodology and parameters in the ODCP implement the requirements in Section III.A of Appendix I that conformance with the guides of Appendix I be shown by calculational procedures based on models and data, such that the actual exposure of a MEMBER OF THE PUBLIC through appropriate pathways is unlikely to be substantially underestimated. The equations specified in the ODCP for calculating the doses due to the actual release rates of radioactive materials in liquid effluents are consistent with the methodology provided in Regulatory Guide 1.109, "Calculation of Annual Doses to Man from Routine Releases of Reactor Effluents for the Purpose of Evaluating Compliance with 10 CFR Part 50, Appendix I," Revision 1, October 1977 and Regulatory Guide 1.113, "Estimating Aquatic Dispersion of Effluents from Accidental and Routine Reactor Releases for the Purpose of Implementing Appendix I," April 1977.

This Regulatory Commitment applies to the release of radioactive materials in liquid effluents from each unit at the site. For units with shared Radwaste Treatment Systems, the liquid effluents from the shared system are to be proportioned among the units sharing that system.

6.1.5 Liquid Radwaste Treatment System

The OPERABILITY of the Liquid Radwaste Treatment System ensures that this system will be available for use whenever liquid effluents require treatment prior to release to the environment. The requirement that the appropriate portions of this system be used when specified provides assurance that the releases of radioactive materials in liquid effluents will be kept "as low as is reasonably achievable." This specification implements the requirements of 10 CFR 50.36a, General Design Criterion 60 of Appendix A to 10 CFR Part 50 and the design objective given in Section II.D of Appendix I to 10 CFR Part 50. The specified limits governing the use of appropriate portions of the Liquid Radwaste Treatment System were specified as a suitable fraction of the dose design objectives set forth in Section II.A of Appendix I, 10 CFR Part 50, for liquid effluents.

This Regulatory Commitment applies to the release of radioactive materials in liquid effluents from each unit at the site. For units with shared Radwaste Treatment Systems, the liquid effluents from the shared system are to be proportioned among the units sharing that system.

PACIFIC GAS AND ELECTRIC COMPANY
INTER-DEPARTMENTAL ADMINISTRATIVE PROCEDURE

NUMBER CY2.ID1
REVISION 6A
PAGE 34 OF 39

TITLE: Radioactive Effluent Controls Program

APPENDIX 6.1 (Continued)

6.1.6 Gaseous Effluents - Dose Rate

This Regulatory Commitment is provided to ensure that the dose at any time at and beyond the SITE BOUNDARY from gaseous effluents from all units on the site will be within the annual dose limits of NUREG 0133 to UNRESTRICTED AREAS. The annual dose limits are the doses to be associated with the concentrations of 10 CFR Part 20, Appendix B, Table 2, Column 1. These limits provide reasonable assurance that radioactive material discharged in gaseous effluents will not result in the exposure of a MEMBER OF THE PUBLIC in an UNRESTRICTED AREA; either within or outside the SITE BOUNDARY, to average concentrations exceeding the limits to be specified in Appendix B, Table 2 of 10 CFR Part 20 (10 CFR Part 20.1302(c)). For MEMBERS OF THE PUBLIC who may at times be within the SITE BOUNDARY, the occupancy of that MEMBER OF THE PUBLIC will usually be sufficiently low to compensate for any increase in the atmospheric diffusion factor above that for the SITE BOUNDARY. Examples of calculations for such MEMBERS OF THE PUBLIC, with the appropriate occupancy factors, shall be given in the ODCP. The specified release rate limits of NUREG 0133 restrict, presently, the corresponding gamma and beta dose rates above background to a MEMBER OF THE PUBLIC at or beyond the SITE BOUNDARY to less than or equal to 500 mrem/year to the whole body or to less than or equal to 3000 mrem/year to the skin. These release rate limits also restrict, at all times, the corresponding thyroid dose rate above background to a child via the inhalation pathway to less than or equal to 1500 mrem/year.

This Regulatory Commitment applies to the release of radioactive materials in gaseous effluents from all units at the site.

The required detection capabilities for radioactive material in gaseous waste samples are tabulated in terms of the lower limits of detection (LLDs). Detailed discussion of the LLD, and other detection limits can be found in Currie, L.A., "Lower Limit of Detection: Definition and Elaboration of a Proposed Position for Radiological Effluent and Environmental Measurements," NUREG/CR-4007 (September 1984), and in the HASL Procedures Manual, HASL-300 (revised annually).

PACIFIC GAS AND ELECTRIC COMPANY
INTER-DEPARTMENTAL ADMINISTRATIVE PROCEDURE

NUMBER CY2.ID1
REVISION 6A
PAGE 35 OF 39

TITLE: Radioactive Effluent Controls Program

APPENDIX 6.1 (Continued)

6.1.7 Dose - Noble Gases

This Regulatory Commitment is provided to implement the requirements of Sections II.B, III.A and IV.A of Appendix I, 10 CFR Part 50. The Limiting Condition for Operation implements the guides set forth in Section II.B of Appendix I. The ACTION statements provide the required operation flexibility and at the same time implement the guides set forth in Section IV.A of Appendix I to assure that the releases of radioactive material in gaseous effluents to UNRESTRICTED AREAS will be kept "as low as is reasonably achievable." The Surveillance Requirements implement the requirements in Section III.A of Appendix I that conformance with the guides of Appendix I be shown by calculational procedures based on models and data such that the actual exposure of a MEMBER OF THE PUBLIC through appropriate pathways is unlikely to be substantially underestimated. The dose calculation methodology and parameters established in the ODCP for calculating the doses due to the actual release rates of radioactive noble gases in gaseous effluents are consistent with the methodology provided in Regulatory Guide 1.109, "Calculation of Annual Doses to Man from Routine Releases of Reactor Effluents for the Purpose of Evaluating Compliance with 10 CFR Part 50, Appendix I," Revision 1, October 1977 and Regulatory Guide 1.111, "Methods for Estimating Atmospheric Transport and Dispersion of Gaseous Effluents in Routine Releases from Light-Water-Cooled Reactors," Revision 1, July 1977. The ODCP equations provided for determining the air doses at and beyond the SITE BOUNDARY are based upon the historical average atmospheric conditions.

This Regulatory Commitment applies to the release of radioactive materials in gaseous effluents from each unit at the site. For units with shared Radwaste Treatment Systems, the gaseous effluents from the shared system are proportioned among the units sharing the system.

PACIFIC GAS AND ELECTRIC COMPANY
INTER-DEPARTMENTAL ADMINISTRATIVE PROCEDURE

NUMBER CY2.ID1
REVISION 6A
PAGE 36 OF 39

TITLE: Radioactive Effluent Controls Program

APPENDIX 6.1 (Continued)

6.1.8 Dose - Iodine-131, Iodine-133, Tritium, and Radioactive Material in Particulate Form

This Regulatory Commitment is provided to implement the requirements of Sections II.C, III.A, and IV.A of Appendix I, 10 CFR Part 50. The Limiting Conditions for Operation are the guides set forth in Section II.C of Appendix I. The ACTION statements provide the required operating flexibility and at the same time implement the guides set forth in Section IV.A of Appendix I to assure that the releases of radioactive materials in gaseous effluents to UNRESTRICTED AREAS will be kept "as low as is reasonably achievable." The ODCP calculational methods specified in the Surveillance Requirements implement the requirements in Section III.A of Appendix I that conformance with the guides of Appendix I be shown by calculational procedures based on models and data, such that the actual exposure of a MEMBER OF THE PUBLIC through appropriate pathways is unlikely to be substantially underestimated. The ODCP calculational methodology and parameters for calculating the doses due to the actual release rates of the subject materials are consistent with the methodology provided in Regulatory Guide 1.109, "Calculation of Annual Doses to Man from Routine Releases of Reactor Effluents for the Purpose of Evaluating Compliance with 10 CFR Part 50, Appendix I," Revision 1, October 1977 and Regulatory Guide 1.111, "Methods for Estimating Atmospheric Transport and Dispersion of Gaseous Effluents in Routine Releases from Light-Water-Cooled Reactors,": Revision 1, July 1977. These equations also provide for determining the actual doses based upon the historical average atmospheric conditions. The release rate specifications for Iodine-131, Iodine-133, tritium, and radionuclides in particulate form with half-lives greater than 8 days are dependent upon the existing radionuclide pathways to man in the areas at and beyond the SITE BOUNDARY. The pathways that were examined in the development of the calculations were: (1) individual inhalation of airborne radionuclides, (2) deposition of radionuclides onto green leafy vegetation with subsequent consumption by man, (3) deposition onto grassy areas where milk animals and meat-producing animals graze with consumption of the milk and meat by man, and (4) deposition on the ground with subsequent exposure of man.

This Regulatory Commitment applies to the release of radioactive materials in gaseous effluents from each unit at the site. For units with shared Radwaste Treatment Systems, the gaseous effluents from the shared system are proportioned among the units sharing that system.

TITLE: Radioactive Effluent Controls Program

APPENDIX 6.1 (Continued)6.1.9 Gaseous Radwaste Treatment System

The OPERABILITY of the GASEOUS RADWASTE SYSTEM and the VENTILATION EXHAUST TREATMENT SYSTEM ensures that the systems will be available for use whenever gaseous effluents require treatment prior to release to the environment. The requirement that the appropriate portions of these systems be used, when specified, provides reasonable assurance that the releases of radioactive materials in gaseous effluents will be kept "as low as is reasonably achievable." This specification implements the requirements of 10 CFR 50.36a, General Design Criterion 60 of Appendix A to 10 CFR Part 50 and the design objectives given in Section II.D of Appendix I to 10 CFR Part 50. The specified limits governing the use of appropriate portions of the systems were specified as a suitable fraction of the dose design objectives set forth in Sections II.B and II.C of Appendix I, 10 CFR Part 50, for gaseous effluents.

This Regulatory Commitment applies to the release of radioactive materials in gaseous effluents from each unit at the site. For units with shared Radwaste Treatment Systems, the gaseous effluents from the shared system are proportioned among the units sharing that system.

6.1.10 Total Dose

This Regulatory Commitment is provided to meet the dose limitations of 40 CFR Part 190 that have been incorporated into 10 CFR Part 20 by 46 FR 18525. The specification requires the preparation and submittal of a Special Report whenever the calculated doses due to releases of radioactivity and to radiation from uranium fuel cycle sources exceed 25 mrem to the whole body or any organ, except the thyroid, which shall be limited to less than or equal to 75 mrem. For sites containing up to four reactors, it is highly unlikely that the resultant dose to a MEMBER OF THE PUBLIC will exceed the dose limits of 40 CFR Part 190 if the individual reactors remain within twice the dose design objectives of Appendix I, and if direct radiation doses from the units and from outside storage tanks are kept small. The Special Report will describe a course of action that should result in the limitation of the annual dose to a MEMBER OF THE PUBLIC to within the 40 CFR Part 190 limits. For the purposes of the Special Report, it may be assumed that the dose commitment to the MEMBER OF THE PUBLIC from other uranium fuel cycle sources is negligible, with the exception that dose contribution from other nuclear fuel cycle facilities at the same site or within a radius of 8 km must be considered. If the dose to any MEMBER OF THE PUBLIC is estimated to exceed the requirements of 40 CFR Part 190, the Special Report with a request for a variance (provided the release conditions resulting in violation of 40 CFR Part 190 have not already been corrected), in accordance with the provisions of 40 CFR 190.11 and 10 CFR 20.2203(a), is considered to be a timely request and fulfills the requirements of 40 CFR Part 190 until NRC staff action is completed. The variance only relates to the limits of 40 CFR Part 190, and does not apply in any way to the other requirements for dose limitation of 10 CFR Part 20, as addressed in Regulatory Commitment 6.1.3.1 and 6.1.6.1. An individual is not considered a MEMBER OF THE PUBLIC during any period in which he/she is engaged in carrying out any operation that is part of the nuclear fuel cycle.

TITLE: Radioactive Effluent Controls Program

APPENDIX 6.2

HIGH ALARM SETPOINTS FOR FUEL BUILDING AND CONTROL ROOM VENTILATION SYSTEMS ACTUATION INSTRUMENTATION

6.2.1 Fuel Building Ventilation System (FBVS) Instrumentation, RE-58 and RE-59

6.2.1.1 RE-58 Nominal Setpoint ≤ 75 mr/hr

Bases

6.2.1.2 Fuel Handling Accident in Fuel Handling Building

- a. The basis for the RE-58 high alarm setpoint is to initiate actions to mitigate offsite dose consequences from air borne releases resulting from a fuel handling accident in the Spent Fuel Pool area. Routing ventilation exhaust from the Spent Fuel Pool area through the charcoal filter, thus stripping halogens (principally iodine isotopes) mitigates offsite dose consequences. The rerouting of the ventilation is accomplished automatically upon receipt of a RE-58 high alarm. Receipt of the high alarm also signals personnel to evacuate the area. PG&E performed a calculation (RA-90-1-0 "High and Alert Alarm Setpoint for RE-58") to base the high alarm setpoint of RE-58 on the airborne radioactivity concentration in the fuel Handling Building for the FSAR Update Expected Case accident release during a fuel handling accident. The Expected Case Accident consequence presented in the FSAR Update is a less severe, but more probable accident than the FSAR Update Design Basis Case fuel handling accident. This resulted in a more conservative (lower) setpoint than that for the Design Basis Accident Case. This calculation analyzed the detector sensitivity to the various release nuclides as presented in the FSAR Update.
- b. The high alarm setpoint is set to a value more consistent with the Expected Case Accident dose rates which eliminates spurious ESF actuation while limiting the offsite consequences due to this accident. A ≤ 75 mr/hr setpoint equates to a site boundary whole body dose of 1.46mr for the duration of the accident, which has been evaluated as being acceptable.

6.2.1.3 Inadvertent Criticality in the Spent Fuel Pool

- a. The high density Spent Fuel Pool racks were redesigned to assure that a K_{eff} equal to or less than 0.95 is maintained with the racks fully loaded with fuel of the highest anticipated reactivity in each of two regions, and flooded with unborated water at a temperature corresponding to the highest reactivity. PG&E submitted PG&E Letter No. DCL-85-30, "Re-racking of Spent Fuel Pools," on September 19, 1985. The results of the criticality analysis for normal and abnormal operations were evaluated in this report. LAR 85-13 (PG&E Letter No. DCL-85-333) was submitted on October 30, 1985, and summarized the results of the Spent Fuel Pool re-racking report. Postulated events that could potentially involve accidental criticality were examined and it was concluded that the limiting value for criticality (K_{eff} of 0.95) would not be exceeded. Therefore, an inadvertent criticality in the Spent Fuel Pool is not considered a credible accident and an evaluation of the effect of raising the actuation setpoint on RE-58 was not required.

TITLE: Radioactive Effluent Controls Program

APPENDIX 6.2 (Continued)

- b. Radiation monitor RE-59, which monitors the new fuel storage vault area, also provides indication of inadvertent criticality and changes in dose rate for radiation protection purposes.

6.2.1.4 RE-59 Nominal Setpoint \leq 15mr/hr

- a. In DCPP FSAR update in Chapter 12, Table 12.1-1, "Plant Zone Classifications," the Fuel Handling Building areas in which RE-59 is located is classified as Zone III, "Controlled Assess Requiring Short-Term Occupancy" as indicated in Design Criteria Memorandum DCM-T20.
- b. The Zone III design maximum dose rate is \leq 15mr/hr. If the radiation flux reaches this value, the high alarm will be actuated and the ventilation mode will change as indicated above with the RE-58 high alarm actuation.

6.2.2 Control Room Ventilation System (CRVS) Instrumentation, RS-25A and RS-26A

6.2.2.1 RS-25A/RS-26A Nominal Setpoint \leq 2 mr/hr

Bases

6.2.2.2 Per calculations DV-1-23 and DV-2-23 attachment 2:

- a. The applicable NRC requirement for the radiation exposure (dose) to personnel in the Main Control Room is 10CFR20.105 "Permissible Level of Radiation in Unrestricted Areas" (superseded). Section b (1) of 10CFR20.105 limits the radiation dose for unrestricted areas to 2mr/hr and Section b (2) limits the dose to 100mr in seven consecutive days. If an operator works in the control room for 48 hours per week (12 hours per day and 4 days per week, a normal operator work week) during a 2mr/hr dose rate, the operator will receive a 96mr dose. This is less than the 100mr/week dose limit of 10CFR20.105 (superseded). Thus, a setpoint of \leq 2 mr/hr has been established for the Control Room Air Inlet Radiation Monitors. If the radiation flux reaches this value at any of the detectors, a change in the ventilation to Mode 4 will be initiated.
- b. 10CFR20.105 has been superseded and any changes to this setpoint will require a basis change to reflect the requirements of 10CFR50 Appendix A Criterion 19.

- 6.2.3 All of the setpoints are controlled by the setpoint control program CF6.ID1 and require a design change vehicle (request per CF4.ID1) to change. Actual field setpoints are set more conservative to account for instrument errors.

Attachment 3

**Off-Site Dose Calculation Procedure
(Procedure CAP A-8 Revision 26)**

PACIFIC GAS AND ELECTRIC COMPANY
 NUCLEAR POWER GENERATION
 DIABLO CANYON POWER PLANT
 CHEMICAL ANALYSIS PROCEDURE

NUMBER CAP A-8
 REVISION 26
 PAGE 1 OF 62
 UNITS

TITLE: Off-Site Dose Calculations

1 AND 2

06/04/02

EFFECTIVE DATE

PROCEDURE CLASSIFICATION: QUALITY RELATED

TABLE OF CONTENTS

<u>SECTION</u>	<u>PAGE</u>
<u>SCOPE</u>	2
<u>DISCUSSION</u>	3
<u>RESPONSIBILITIES</u>	3
<u>PREREQUISITES</u>	3
<u>PRECAUTIONS</u>	4
<u>INSTRUCTIONS</u>	4
Liquid Effluents	4
Liquid Effluents - Dose Calculation	4
10 CFR 20, Appendix B, Table 2, Column 2, Effluent (liquid) Concentration Limit (ECL) Calculation	6
Liquid Effluent Radiation Monitor Set Point Methodology	7
Dose Projection (for Liquid Effluents)	13
Liquid Limiting Flow Rate Methodology - ECL Based	15
Liquid Limiting Flow Rates - LLD Based	16
Gaseous Effluents	18
Plant Vent Noble Gas Monitor - RE-14 HASP	21
Containment Purge - RE-44 HASP	28
Dose To Critical Receptor Due To Radioiodines, Tritium and Particulates Released in Gaseous Effluents	34
40 CFR 190 Dose Calculations	42
<u>ACCEPTANCE CRITERIA</u>	47
<u>REFERENCES</u>	47
<u>RECORDS</u>	47
<u>APPENDICES</u>	48
<u>ATTACHMENTS</u>	48
<u>SPONSOR</u>	48
 Table 6.1 - Typical Liquid Effluent Discharge Pathway Allocation Factors	8
Table 6.2 - Typical Gaseous Effluent Discharge Pathway Allocation Factors	20
Table 6.3 - Expected On-Site Distance and Visitation Times for Members of the Public	46

**PACIFIC GAS AND ELECTRIC COMPANY
DIABLO CANYON POWER PLANT**

**NUMBER CAP A-8
REVISION 26
PAGE 2 OF 62
UNITS 1 AND 2**

TITLE: Off-Site Dose Calculations

1. SCOPE

This procedure describes the methodology for the following:

Effluent Type	RECP or Tech Spec	RECP or Tech Spec Surveillance Requirement	Implements
Liquids	6.1.1.1 (RECP) 6.1.3.1 (RECP)	Determination of alarm/trip setpoints for RE-18, RE-23, and RE-3	10 CFR 20 App. B Table 2, Col. 2
Gases	6.1.2.1 (RECP) 6.1.6.1 (RECP)	Determination of alarm/trip setpoints for RE-22, RE-14, and RE-14R	NUREG 0133
Liquids	6.1.3.2 (RECP) 6.1.3.3 (RECP)	Prerelease analyses of effluents Postrelease analysis of effluents	10 CFR 20 App. B Table 2, Col. 2
Liquids	6.1.4.2 (RECP)	Dose calculations	10 CFR 50 App. I
Liquids	6.1.5.2 (RECP)	Dose projections	10 CFR 50 App. I
Gases	6.1.6.2	Dose Rate calculations, Noble Gases, Total Body and Skin	NUREG 0133
Gases	6.1.6.3	Dose Rate calculations, Iodines, Particulates and Radionuclides other than Noble Gases, per organ, per age group	NUREG 0133
Gases	6.1.7.2 (RECP)	Noble Gas Air Dose Calculations	10 CFR 50 App. I
Gases	6.1.8.2 (RECP)	Iodines, Particulates, and Radionuclides other than Noble Gases Organ Dose Calculations per age group	10 CFR 50 App. I
Gases	6.1.9.2 (RECP)	Noble Gases, Iodines, Particulates, and Radionuclides other than Noble Gases, Dose Projection	10 CFR 50 App. I
Liquids and Gases	6.1.10.2 (RECP) 4.4.2.b.1 (RECP)	Cumulative Dose from: Liquids, Noble Gases, Iodines, Particulates, and Radionuclides other than Noble Gases per age group, per organ	40 CFR 190
Direct Radiation	6.1.10.3 (RECP)	Direct Radiation Dose Rate and Dose Calculations to unrestricted areas due to plant and high radwaste storage sky-shine	40 CFR 190

The calculational methodology for doses are based on models and data that make it unlikely to substantially underestimate the actual exposure of an individual through any of the appropriate pathways. Tables containing the values for the various parameters used in these expressions are also included.

**PACIFIC GAS AND ELECTRIC COMPANY
DIABLO CANYON POWER PLANT**

**NUMBER CAP A-8
REVISION 26
PAGE 3 OF 62
UNITS 1 AND 2**

TITLE: Off-Site Dose Calculations

2. DISCUSSION

- 2.1 This procedure is used in support of the Radiological Monitoring and Controls Program (RMCP), and Radioactive Effluent Controls Program (RECP), and the portion that deals with routine radioactive liquid and gaseous releases to the unrestricted area. Limits are based on the dose commitment to a member of the general public related to the release of radionuclides through either direct or indirect exposure (e.g., submersion in a cloud of radioactive Noble Gases, radionuclides deposited on the ground, direct radiation from radionuclides stored on-site, inhalation of radionuclides or ingestion of radionuclides via a food pathway such as milk, meat, vegetable or fish, etc.).
- 2.2 The conduct of the Environmental Radiological Monitoring Procedure (ERMP) is found in RP1.ID11.
- 2.3 Changes to CAP A-8 shall be processed in accordance with the requirements of DCP Technical Specification Section 5.5.1.

3. RESPONSIBILITIES

- 3.1 The Director, Chemistry is the overseeing authority of responsibility for ensuring that the off-site dose calculational procedure (ODCP) meets all RECP and Tech Spec requirements with regards to calculated doses delivered by the plant to the unrestricted area surrounding the site.
- 3.2 The Senior Radiochemistry Engineer assumes the overall responsibility for ensuring that this procedure's program is followed and implemented where appropriate, especially in regards to RECP or Tech Spec requirements.
- 3.3 The Radiochemistry Effluents Engineer has the responsibility of correct and timely implementation of all the procedure's calculational methodology, where appropriate, for each radioactive effluent released. Furthermore this engineer is responsible for: reviewing the results; cross (spot) checking the calculations; and maintaining an updated archive of post release calculated doses for annual report purposes.
- 3.4 The Senior Engineer Tech Maintenance Computer Group assures that any supporting computer software is maintained current and compatible with the procedure's calculational methodology and that the computer hardware is maintained operable at all times.
- 3.5 The Radiochemistry staff engineer provides an oversight of the effluents program's ODCP to: confirm compliance with RECP or Tech Specs; provide technical support; recommend or design improvements to the dose calculational methodology and the effluent program control; and investigate long-term planning toward effluent related activities and their associated dose calculations.
- 3.6 Responsibilities as described in CY1, "Chemistry and Radiochemistry," and CY1.DC1, "Analytical Data Processing Responsibilities," apply.

4. PREREQUISITES

Not Applicable

**PACIFIC GAS AND ELECTRIC COMPANY
DIABLO CANYON POWER PLANT**

**NUMBER CAP A-8
REVISION 26
PAGE 4 OF 62
UNITS 1 AND 2**

TITLE: Off-Site Dose Calculations

5. PRECAUTIONS

Not Applicable

6. INSTRUCTIONS

6.1 Liquid Effluents

6.1.1 Liquid Effluents - Dose Calculation

The dose contributions to the total body and each individual organ (bone, liver, thyroid, kidney, lung and GI-LLI) of the maximum exposed individual (adult) due to consumption of saltwater fish and saltwater invertebrate is calculated for all radionuclides identified in liquid effluents released to unrestricted areas using the following expression:

$$D_o = F_t \Delta t \sum_i A_{i0} C_i e^{-\lambda_i t_m} \tag{1}$$

Where:

D_o = The dose commitment to organ, o, in mrem.

F_t = Near field average dilution factor during the period of the release. It is defined as:

$$F_t = \frac{\text{Waste Flow}}{\text{Dilution Flow} \times Z} \tag{2}$$

Where:

Z = Z is the site specific factor for the mixing effect of the discharge structure. Specifically, it is the credit taken for dilution which occurs between the discharge structure and the body of water which contaminates fish or invertebrates in the liquid ingestion pathway. For DCP $Z = 5$.

Δt = The time period for the release in hours.

A_{i0} = The site specific ingestion dose commitment factor to organ, o, due to radionuclide, i, in mrem/hr per $\mu\text{Ci/ml}$ as defined by Equation 3.

C_i = Concentration of radionuclide, i, in the undiluted liquid effluent, in $\mu\text{Ci/ml}$.

λ_i = Decay constant of radionuclide, i.

t_m = Time interval between end of sampling and midpoint of release.

PACIFIC GAS AND ELECTRIC COMPANY
DIABLO CANYON POWER PLANT

NUMBER CAP A-8
REVISION 26
PAGE 5 OF 62
UNITS 1 AND 2

TITLE: Off-Site Dose Calculations

The site specific ingestion dose commitment factor, A_{10} , is defined as:

$$A_{10} = k_o (U_F BF_i + U_I BI_i) DF_i \quad (3)$$

Where:

- k_o = Units conversion factor of 1.14×10^5 in units of $\rho\text{Ci}/\mu\text{Ci} \times \text{ml/l} \times \text{yr/hr}$.
- U_F = Saltwater fish consumption rate in kilograms of fish per year. DCPD value for this parameter is 21 kg/yr and is taken from NUREG 0133, Section 4.3.1.
- BF_i = Saltwater bioaccumulation factor for nuclide, i , in fish flesh in units of $\rho\text{Ci/Kg}$ per $\rho\text{Ci/l}$. Values for BF_i are taken from Table A-1 of Reg. Guide 1.109.
- U_I = Saltwater invertebrate consumption rate in kilograms per years. DCPD value for this parameter is 5 kg/yr and is taken from NUREG 0133, Section 4.3.1.
- BI_i = Saltwater bioaccumulation factor for nuclide, i , in invertebrate flesh in units of $\rho\text{Ci/Kg}$ per $\rho\text{Ci/l}$. Values for BI_i are taken from Table A-1 of Reg. Guide 1.109.
- DF_i = Adult ingestion dose conversion factor for nuclide, i , in mrem per ρCi ingested, from Table E-11 of Regulatory Guide 1.109, with the following exceptions: H-3, Br-82, Sb-124 and Sb-125 ingestion dose conversion factors are taken from NUREG/CR-4013. As-76, Sn-113, Sn-117m and Sb-122 ingestion dose conversion factors were calculated by ORNL using ICRP-2 methodology.

The site specific values for A_{10} are listed in Table 10.1.

Units 1 and 2 share a common liquid radwaste (LRW) treatment system. The effluent doses due to releases discharged via the common LRW are apportioned between the units with 50% credited to Unit 1 and 50% credited to Unit 2.

PACIFIC GAS AND ELECTRIC COMPANY
DIABLO CANYON POWER PLANT

NUMBER CAP A-8
REVISION 26
PAGE 6 OF 62
UNITS 1 AND 2

TITLE: Off-Site Dose Calculations

6.1.2 10 CFR 20, Appendix B, Table 2, Column 2, Effluent (liquid) Concentration Limit (ECL) Calculation

- a. The ECL for the identified mixture of radionuclides in the "jth" batch of liquids is calculated as follows:

$$ECL_j = \frac{\sum_{i=1}^n C_{ij}}{\sum_{i=1}^n \frac{C_{ij}}{ECL_{ij}}} \quad (4)$$

Where:

- ECL_j = The unrestricted area total undiluted ECL for the "jth" particular mixture of identified radionuclides, in $\mu\text{Ci/ml}$.
- C_{ij} = The concentration of radionuclide "i," in $\mu\text{Ci/ml}$ for the "jth" mixture.
- ECL_{ij} = The ECL in unrestricted area water for radionuclide "i," in general, in $\mu\text{Ci/ml}$ (from 10 CFR 20, Appendix B, Table 2, Column 2).

PACIFIC GAS AND ELECTRIC COMPANY
DIABLO CANYON POWER PLANT

NUMBER CAP A-8
REVISION 26
PAGE 7 OF 62
UNITS 1 AND 2

TITLE: Off-Site Dose Calculations

b. The overall ECL for simultaneous discharges is given by Equation 5.

$$ECL_{overall} = \frac{\sum_{j=1}^n \Phi_j C_j}{\sum_{j=1}^n \frac{\Phi_j C_j}{ECL_j}} \quad (5)$$

Where:

$ECL_{overall}$ = The unrestricted area ECL for the current radionuclide mixture for concurrent "j" discharges (in $\mu\text{Ci/ml}$).

C_j = The total activity concentration for the "jth" individual stream in $\mu\text{Ci/ml}$.

ECL_j = The total ECL for the "jth" individual mixture (or stream) determined as defined in Equation 4, in $\mu\text{Ci/ml}$.

Φ_j = The ratio of an individual discharge "jth" pathway flowrate to the sum total of all individual undiluted pathway flowrates as defined by:

$$\Phi_j = \frac{f_j}{\sum_j f_j} \quad (6)$$

Where:

f_j = Undiluted effluent flowrate for pathway, "j".

6.1.3 Liquid Effluent Radiation Monitor Set Point Methodology

a. Introduction

The DCCP radiological effluent controls program requires that the liquid effluent monitors be operable with their alarm/trip set points set to ensure that the effluent concentration limits of 10 CFR 20 are not exceeded.

The alarm/trip set point for the liquid effluent radiation monitors is derived from the concentration limit set forth in Appendix B, Table 2, Column 2 of 10 CFR 20.1001-2404.

The alarm/trip set points are applied at the unrestricted area boundary. The set points take into account appropriate factors for dilution, dispersion, or decay of radioactive materials that may occur between the point of discharge and the unrestricted area boundary.

**PACIFIC GAS AND ELECTRIC COMPANY
DIABLO CANYON POWER PLANT**

**NUMBER CAP A-8
REVISION 26
PAGE 8 OF 62
UNITS 1 AND 2**

TITLE: Off-Site Dose Calculations

b. Allocation and Safety Factors

The limits of RECP 6.1.3.1 are site limits which require that the set point methodology must ensure simultaneous releases do not exceed the liquid effluent concentration limits of 10 CFR 20 in the unrestricted area. The DCPD High Alarm Set Point (HASP) methodology makes use of an Allocation Factor (AF) to limit the effluent concentrations from simultaneous liquid discharges. The Allocation Factors can be adjusted based upon operational requirements with the restriction that the sum of the Allocation Factors must be less than or equal to 1.

Typical Allocation Factors are shown Table 6.1.

**Table 6.1
Typical Liquid Effluent Discharge Pathway Allocation Factors**

Discharge Pathway	Rad Monitor	Allocation Factor (AF)
Oily Water Separator	RE-3	0.01
Liquid Radwaste System	RE-18	0.90
Steam Generator Blow Down (Unit 1)	RE-23 (U1)	0.04
Steam Generator Blow Down (Unit 2)	RE-23 (U2)	0.04
Miscellaneous	none	0.01

An additional level of conservatism in the HASP methodology is implemented by the use of a Safety Factor (SF). The Safety Factor is defined as 0.9 and provides for a High Alarm Set Point at 90% of the 10 CFR 20 concentration limits.

c. Tritium Correction Factor

As result of an aggressive liquid radwaste treatment program, the liquid effluents at DCPD typically contain very low levels of gamma emitters. In order to reduce the over all volume of liquid waste discharged, DCPD also recycles waste water. This recycling results in higher tritium concentration in liquid effluents when compared with the low gamma emitter concentrations. As a result, standard HASP methodology results in very low set points. In some cases the calculated set points are barely above the monitor background.

The liquid HASP methodology used by DCPD uses a Tritium Correction Factor (TCF) which assumes a constant, but conservative tritium concentration in the liquid effluent. This results in an operationally reasonable set point while ensuring that the liquid effluent concentrations released to the unrestricted areas do not exceed the limits of 10 CFR 20.

PACIFIC GAS AND ELECTRIC COMPANY
DIABLO CANYON POWER PLANT

NUMBER CAP A-8
REVISION 26
PAGE 9 OF 62
UNITS 1 AND 2

TITLE: Off-Site Dose Calculations

The Tritium Correction Factor is defined as shown in Equation 7.

$$TCF = \left[1 - \left(\frac{C_{H3}/ECL_{H3}}{F/f} \right) \right] \quad (7)$$

Where:

- ECL_{H3} = effluent concentration limit of tritium
- C_{H3} = concentration of tritium in the release mix, pre-dilution (μCi/ml)
- F = conservative dilution flow rate (gpm)
- f = conservative undiluted effluent flow rate (gpm)

The concentration of tritium, C_{H3}, is conservatively estimated.

d. Liquid Effluent Radiation Monitor Set Point Calculations

The High Alarm Set Point (HASP) are calculated to ensure that the liquid effluent concentration limits of 10 CFR 20 are not exceeded. The set points represent the maximum operational set point. The actual set point used by operations will be equal to or less than the actual value as determined by the HASP methodology described in this section.

1. Set Point Methodology for RE-3 HASP: Oily Water Separator

Under normal conditions, the Oily Water Separator stream does not contain any radioactive material. Only in the event that there is primary to secondary leakage does this become a potential liquid effluent discharge point. In order to insure that no unplanned or unmonitored releases take place by way of the Oily Water Separator, RE-3 serves to monitor the discharge even when no activity has been identified in the effluent. When no significant primary to secondary leakage is taking place or when no activity has been identified in the Oily Water Separator, the High Alarm Set Point for RE-3 is calculated as shown in Equation 8.

$$HASP_{RE-3} = 3 \times BKG D_{RE-3} \quad (8)$$

PACIFIC GAS AND ELECTRIC COMPANY
DIABLO CANYON POWER PLANT

NUMBER CAP A-8
REVISION 26
PAGE 10 OF 62
UNITS 1 AND 2

TITLE: Off-Site Dose Calculations

In the event that primary to secondary leakage results in activity being detected in the Oily Water Separator, Equation 9 will be used to calculate a High Alarm Set Point value. The greater HASP value as determined by Equation 8 or Equation 9 will be used.

$$HASP_{RE-3} = BKGD_{RE-3} + (AF)(SF) \times \sum_{\gamma} k_{\gamma} C_{\gamma} \left[\frac{F/f}{\sum_{i \neq H3} C_i / ECL_i} \right] \times TCF \quad (9)$$

Where:

- HASP_{RE-3} = high alarm setpoint for RE-3 (cpm)
- BKGD_{RE-3} = background reading for RE-3 (cpm)
- (AF) = allocation factor for the oily water separator effluent system from Table 6.1
- (SF) = safety factor for RE-3 (0.9)
- k_γ = monitor response factor (cpm/μCi/ml)
- C_γ = concentration of gamma emitting isotopes in the release mix, pre-dilution (μCi/ml)
- F = dilution flow rate (gpm)
- f = undiluted effluent flow rate (gpm)
- C_i = concentration of isotope "i," in the release mix, pre-dilution (μCi/ml)
- ECL_i = effluent concentration limit of isotope "i"
- TCF = tritium correction factor as defined by Equation 7.

PACIFIC GAS AND ELECTRIC COMPANY
 DIABLO CANYON POWER PLANT

NUMBER CAP A-8
 REVISION 26
 PAGE 11 OF 62
 UNITS 1 AND 2

TITLE: Off-Site Dose Calculations

2. Set Point Methodology for RE-18 HASP: Liquid Radwaste System

The High Alarm Set Point for the RE-18 Liquid Radwaste System liquid effluent radiation monitor is calculated as shown in Equation 10.

$$HASP_{RE-18} = BKGD_{RE-18} + (AF)(SF) \times \sum_{\gamma} k_{\gamma} C_{\gamma} \left[\frac{F/f}{\sum_{i \neq H3} C_i / ECL_i} \right] \times TCF \quad (10)$$

Where:

HASP_{RE-18} = high alarm setpoint for RE-18 (cpm)

BKGD_{RE-18} = background reading for RE-18 (cpm)

(AF) = allocation factor for the liquid radwaste effluent system from Table 6.1

(SF) = safety factor for RE-18 (0.9)

k_γ = monitor response factor (cpm/μCi/ml)

C_γ = concentration of gamma emitting isotopes in the release mix, pre-dilution (μCi/ml)

F = dilution flow rate (gpm)

f = undiluted effluent flow rate (gpm)

C_i = concentration of isotope "i," in the release mix, pre-dilution (μCi/ml)

ECL_i = effluent concentration limit of isotope "I"

TCF = tritium correction factor as defined by Equation 7.

PACIFIC GAS AND ELECTRIC COMPANY
 DIABLO CANYON POWER PLANT

NUMBER CAP A-8
 REVISION 26
 PAGE 12 OF 62
 UNITS 1 AND 2

TITLE: Off-Site Dose Calculations

3. Set Point Methodology for RE-23 HASP: Steam Generator Blowdown Tank

The High Alarm Set Point for the RE-23, Steam Generator Blowdown Tank liquid effluent radiation monitor, is calculated as shown in Equation 11.

$$HASP_{RE-23} = BKGD_{RE-23} + (AF)(SF) \times \sum_{\gamma} k_{\gamma} C_{\gamma} \left[\frac{F/f}{\sum_{i \neq H3} C_i / ECL_i} \right] \times TCF \quad (11)$$

Where:

- HASP_{RE-23} = high alarm setpoint for RE-23 (cpm)
- BKGD_{RE-23} = background reading for RE-23 (cpm)
- (AF) = allocation factor for the steam generator blowdown effluent system for each unit from Table 6.1
- (SF) = safety factor for RE-23 (0.9)
- k_γ = monitor response factor (cpm/μCi/ml)
- C_γ = concentration of gamma emitting isotopes in the release mix, pre-dilution (μCi/ml)
- F = dilution flow rate (gpm)
- f = undiluted effluent flow rate (gpm)
- C_i = concentration of isotope "i," in the release mix, pre-dilution (μCi/ml)
- ECL_i = effluent concentration limit of isotope "i"
- TCF = tritium correction factor as defined by Equation 7.

PACIFIC GAS AND ELECTRIC COMPANY
DIABLO CANYON POWER PLANT

NUMBER CAP A-8
REVISION 26
PAGE 13 OF 62
UNITS 1 AND 2

TITLE: Off-Site Dose Calculations

6.1.4 Dose Projection (for Liquid Effluents)

The projected dose contributions from each reactor unit due to liquid effluents for the current calendar month, quarter and current calendar year must be determined in accordance with the methodology and parameters in the ODCP at least every 31 days.

The purpose of this is to determine if appropriate treatment of liquid radioactive materials in relation to maintaining releases "as low as reasonably achievable," is necessary.

Projections will be made, at least by the end of each month with attention to the frequency requirement contained in the radiological effluent controls program.

The projected dose from each reactor unit is given by:

$$D_P = D_{P,U} + \frac{1}{2} D_{P,Com} \tag{12}$$

Where:

D_P = Projected Dose.

$D_{P,U}$ = Projected dose attributed to reactor unit, U.

$D_{P,Com}$ = Projected dose common to both reactor units.

The 31-day projected dose is calculated by Equation 13.

$$D_P^M = 31 \times \frac{D_A^{PM} + d_A^{CM} + d_P^{CB}}{(T + t)} \tag{13}$$

Where:

D_P^M = Monthly Projected Dose

D_A^{PM} = Previous Month's Actual Dose

d_A^{CM} = Current Month Actual Dose to date

d_P^{CB} = Projected Dose from Current Batch Release

T = Number of days in the previous month

t = Number of days into the present month

PACIFIC GAS AND ELECTRIC COMPANY
DIABLO CANYON POWER PLANT

NUMBER CAP A-8
REVISION 26
PAGE 14 OF 62
UNITS 1 AND 2

TITLE: Off-Site Dose Calculations

Projected quarterly doses are determined by Equation 14.

$$D_p^{CQ} = d_A^{CQ} + (92 - t) \frac{D_A^{PQ} + d_A^{CQ} + d_P^{CB}}{(T + t)} \quad (14)$$

Where:

- D_p^{CQ} = Projected dose for the current calendar quarter.
- d_A^{CQ} = Current quarter to date actual dose.
- D_A^{PQ} = Previous quarter's actual dose.
- d_P^{CB} = Projected dose as a result of the current batch release.
- T = Number of days in the previous quarter.
- t = Number of days into the present quarter.

Projected yearly doses are determined by Equation 15.

$$D_p^{CY} = d_A^{CY} + (366 - t) \frac{D_A^{PY} + d_A^{CY} + d_P^{CB}}{(T + t)} \quad (15)$$

Where:

- D_p^{CY} = Projected dose for the current calendar year.
- d_A^{CY} = Current year to date actual dose.
- D_A^{PY} = Previous year's actual dose.
- d_P^{CB} = Projected dose as a result of the current batch release.
- T = Number of days in the previous year.
- t = Number of days into the present year.

PACIFIC GAS AND ELECTRIC COMPANY
DIABLO CANYON POWER PLANT

NUMBER CAP A-8
REVISION 26
PAGE 15 OF 62
UNITS 1 AND 2

TITLE: Off-Site Dose Calculations

6.1.5 Liquid Limiting Flow Rate Methodology - ECL Based

The maximum effluent flow rate through monitors RE-3, RE-18, and RE-23 as well as for releases from the Condensate Demineralizer Regenerate waste tank or miscellaneous release points is established in order to provide further control over the effluent releases. The release rate limit is determined by the effluent concentration and the 10 CFR 20 Effluent Concentration Limits (ECLs) as shown in Equation 16.

$$f = \frac{F(AF)(SF)(TCF)}{\sum_{i \neq H-3} \frac{C_i}{ECL_i}} \quad (16)$$

Where:

- f = Maximum operational undiluted liquid radwaste effluent discharge flow rate (gpm)
- F = Expected dilution flow rate (gpm)
- AF = allocation factor for the liquid radwaste effluent source from Table 6.1.
- SF = safety factor (0.9).
- TCF = tritium correction factor as defined by Equation 7.
- C_i = concentration of isotopes "i" in the release mix, pre-dilution (μCi/ml)
- ECL_i = effluent concentration limit of isotope "i" (μCi/ml)

When the term $\sum_{i \neq H-3} \frac{C_i}{ECL_i} = 0$ then the Limiting Flow Rate is calculated by:

$$f = F(AF)(SF)(TCF) \quad (17)$$

Where the terms are as previously defined.

PACIFIC GAS AND ELECTRIC COMPANY
DIABLO CANYON POWER PLANT

NUMBER CAP A-8
REVISION 26
PAGE 16 OF 62
UNITS 1 AND 2

TITLE: Off-Site Dose Calculations

6.1.6 Liquid Limiting Flow Rates - LLD Based

When there is no primary to secondary leakage, the Oily Water Separator and various miscellaneous release points are assumed to be uncontaminated. Furthermore, in order to establish practical operational flow rate limits for any sources when they are considered uncontaminated, Equation 18 is used. While no activity may be present, Equation 18 assumes a concentration equal to the Lower Limit of Detection for the nuclides listed in CY2.ID1, Appendix 6.1, Table 6.1.3-1.

$$f = \frac{F(AF)(SF)}{4.3} \quad (18)$$

Where:

- f = Maximum operational undiluted liquid radwaste effluent discharge flow rate (gpm)
- F = Expected dilution flow rate (gpm)
- AF = allocation factor for the liquid radwaste effluent source from Table 6.1.
- SF = safety factor (0.9).
- 4.3 = Total ECL fraction as given by:

$$\sum_i \frac{LLD_i}{ECL_i}$$

Where:

- LLD_i = Lower limit of detection for isotope "i" from CY2.ID1, Appendix 6.1, Table 6.1.3-1. (μCi/ml)
- ECL_i = effluent concentration limit of isotope "i" (μCi/ml)

PACIFIC GAS AND ELECTRIC COMPANY
DIABLO CANYON POWER PLANT

NUMBER CAP A-8
REVISION 26
PAGE 17 OF 62
UNITS 1 AND 2

TITLE: Off-Site Dose Calculations

6.1.7 Unplanned Liquid Releases (Abnormal Releases)

An unplanned release is an unexpected and potentially unmonitored release to the environment due to operational error or equipment malfunctions.

- a. Unmonitored unplanned releases shall have a report written by the Radiochemistry Effluents Engineer describing the event with a calculation, if possible, of the percent of Tech Spec release rate limit. This will then be forwarded to PSRC for review. Describe these unplanned releases in the Annual Radioactive Effluent Release Report.
- b. Monitored unplanned releases which exceed 1% of the RECP release rate limit will also have a report written describing the event and must be forwarded to the PSRC for review. Describe these unplanned releases in the Annual Radioactive Effluent Release Report.

PACIFIC GAS AND ELECTRIC COMPANY
DIABLO CANYON POWER PLANT

NUMBER CAP A-8
REVISION 26
PAGE 18 OF 62
UNITS 1 AND 2

TITLE: Off-Site Dose Calculations

6.2 Gaseous Effluents

The only significant path for gaseous radioactive releases to the environment during normal operations is via the plant vent. This source is used for calculating dose rates and real-time doses to the unrestricted area due to noble gases, vaporous radioiodines and airborne radio-particulates. The plant vent also has redundant monitoring for these types of gaseous releases.

Other paths such as the steam generator blowdown tank vent, the chemistry lab fume hood, the main condenser Nash vacuum pump discharge, hot machine shop vent, etc., are considered miscellaneous release sources. These miscellaneous release sources are not continuously monitored but can have dose rates and dose calculated for their path to the unrestricted area.

6.2.1 Meteorological Methodology

The equations for determining gaseous effluent concentration limits, high alarm setpoints, dose rates, and critical receptor doses make use of the historical average atmospheric conditions in accordance with methodologies of Regulatory Guides 1.109 and 1.111 and NUREGs 0133 and 0472. The historical average dispersion (χ/Q) and deposition (D/Q) values are derived from the methodology of Regulatory Guide 1.111 as implemented by NUREG 2919 (computer code XOQDOQ). The DCPD dispersion and deposition values are based on the latest five years of meteorological data and are updated when the value of χ/Q or D/Q changes by more than ten percent. The present values are listed in Table 10.2.

Long-term releases are characterized as those that are generally continuous and stable in release rate, such as normal ventilation systems effluents. Doses due to long-term releases are modeled using historical annual average dispersion and deposition values in accordance with the guidance of Regulatory Guide 1.109, Regulatory Guide 1.111, NUREG 0133 and NUREG 0472.

Short-term releases are defined as those which occur for a total of 500 hours or less in a calendar year but not more than 150 hours in any quarter. In accordance with NUREG 0133 and based upon an operational history that has demonstrated short term gaseous releases can be characterized as random in both time of day and duration, historical average atmospheric dispersion and deposition values are used to model doses due to short-term releases.

**PACIFIC GAS AND ELECTRIC COMPANY
DIABLO CANYON POWER PLANT**

**NUMBER CAP A-8
REVISION 26
PAGE 19 OF 62
UNITS 1 AND 2**

TITLE: Off-Site Dose Calculations

6.2.2 Gas Effluent Concentration Limits

a. Philosophy of Concentration Limits

The radiological effluent controls restrict at all times the dose rate due to radioactive materials released in gaseous effluents from the site to areas at or beyond the site boundary for noble gases to less than or equal to 500 mrem/yr to the total body and 3000 mrem/yr to the skin. For iodine-131, iodine-133, tritium and for all radionuclides in particulate form with half-lives greater than 8 days, the dose rate is limited to less than or equal to 1500 mrem/yr to any organ.

These dose rate limits act to restrict at all times the instantaneous concentrations of radionuclides in gaseous effluents at the site boundary.

1. Allocation and Safety Factors

The limits set forth by RECP 6.1.6.1 are site limits which require that the set point methodology must ensure simultaneous releases do not exceed the off-site dose rate limits set forth by RECP 6.1.6.1(a) and 6.1.6.1(b). The DCP High Alarm Set Point methodology makes use of an Allocation Factor (AF) to limit the noble gas effluent dose rate from simultaneous atmospheric releases.

The Allocation Factors can be adjusted based upon operational requirements with the following restrictions:

The sum of the Allocation Factors for RE-14 (plant vent noble gas monitor), the SGBD tank vents, and miscellaneous release points from both units must be less than or equal to 1.

The Allocation Factors for RE-22 (Waste Gas Decay Tanks) and RE-44 (Containment Purge) can also be adjusted based upon operational requirements with restriction that the sum of the Allocation Factors for RE-22 and RE-44 must be less than or equal to the Allocation Factor for RE-14.

The Allocation Factors for RE-24 (Plant Vent Iodine Monitor) and RE-28 (Plant Vent Particulate Monitor) are set equal to the Allocation Factor for RE-14.

PACIFIC GAS AND ELECTRIC COMPANY
DIABLO CANYON POWER PLANT

NUMBER CAP A-8
REVISION 26
PAGE 20 OF 62
UNITS 1 AND 2

TITLE: Off-Site Dose Calculations

Typical Allocation Factors are shown in Table 6.2.

Table 6.2

Typical Gaseous Effluent Discharge Pathway Allocation Factors

Discharge Pathway	Rad Monitor	Allocation Factor (AF)
Plant Vent - NG Monitor	RE-14	0.48
Plant Vent Iodine Monitor	RE-24	0.48
Plant Vent Part Monitor	RE-28	0.48
Waste Gas Decay Tank	RE-22	0.10
Containment Purge	RE-44	0.38
SGBD Tank Vent		0.01
Miscellaneous		0.01

An additional level of conservatism in the HASP methodology is implemented by the use of a Safety Factor (SF). The Safety Factor is defined as 0.9 and provides for a High Alarm Set Point at 90% of the dose rate limits.

PACIFIC GAS AND ELECTRIC COMPANY
 DIABLO CANYON POWER PLANT

NUMBER CAP A-8
 REVISION 26
 PAGE 21 OF 62
 UNITS 1 AND 2

TITLE: Off-Site Dose Calculations

b. Gaseous Effluent Radiation Monitor Set Points

1. PLANT VENT NOBLE GAS MONITOR - RE-14 HASP

The Plant Vent effluent stream is monitored by rad monitor RE-14. RE-14 provides alarm function only. The High Alarm Set Point methodology for RE-14 is given by Equation 19, which is based upon the assumption that the total body dose rate limit is most limiting.

$${}^{14}\text{Max} C_T(\text{NG}) = AF \times SF \times \frac{500}{472 \times F_{pv} \times (\overline{\chi/Q})_{\text{Max}} \times 294} \quad (19)$$

Where:

- ${}^{14}\text{Max} C_T(\text{NG})$ = the maximum allowable total concentration of noble gas in the plant vent, in $\mu\text{Ci/cc}$
- AF = the allocation factor for the plant vent for one unit from Table 6.2
- SF = a safety factor to ensure that dose rate limits of the radiological effluent controls are not exceeded (0.9)
- 500 = (mrem/yr) the site Total Body dose rate limit for instantaneous releases
- 472 = the conversion constant to cc/sec from cfm
- F_{pv} = total flow rate in the plant vent, in cfm (maximum plant vent flow rate is 263,000 cfm)
- $(\overline{\chi/Q})_{\text{Max}}$ = the maximum historical site boundary dispersion factor, based on 5 year averages derived from the meteorological data base, from Table 10.2.
- 294 = the whole body dose factor (mrem/yr/ $\mu\text{Ci/m}^3$) for Xe-133 as presented in Table 10.3, (for the plant vent HASP, the release is assumed to be all Xe-133)

PACIFIC GAS AND ELECTRIC COMPANY
DIABLO CANYON POWER PLANT

NUMBER CAP A-8
REVISION 26
PAGE 22 OF 62
UNITS 1 AND 2

TITLE: Off-Site Dose Calculations

2. PLANT VENT NOBLE GAS MONITOR - RE-14 SCALING

In order to correlate the readings of RE-14 to noble gas concentration during periods between samplings, the concentration is scaled according to Equation 20.

$$C_T = \frac{CPM_T}{CPM_S} \times C_S \qquad (20)$$

Where:

CPM_T = RE-14 time weighted arithmetic mean (cpm).

CPM_S = RE-14 gross count rate at the time of sampling (cpm).

C_S = Concentration of noble gas corresponding to CPM_S , based upon noble gas grab sample ($\mu\text{Ci/cc}$).

C_T = Scaled concentration of noble gas ($\mu\text{Ci/cc}$).

PACIFIC GAS AND ELECTRIC COMPANY
 DIABLO CANYON POWER PLANT

NUMBER CAP A-8
 REVISION 26
 PAGE 23 OF 62
 UNITS 1 AND 2

TITLE: Off-Site Dose Calculations

3. PLANT VENT IODINE MONITOR - RE-24

The Plant Vent Iodine concentration is monitored by rad monitor RE-24. RE-24 provides alarm function only. The alarm setpoint methodology is based upon the assumption that RE-24 responds only to I-131. The methodology also presumes a release mixture based upon the RCS source term.

The High Alarm Set Point methodology of RE-24 is given by Equation 21.

$${}^{24\text{Max}}C_T(\text{Iodine}) = SF \times AF \times f_{I-131} \frac{1500}{472 \times F_{pv} \times (\chi/Q)_{\text{Max}} \sum_i P_i^w f_i} \quad (21)$$

Where:

- ${}^{24\text{Max}}C_T(\text{Iodine})$ = the maximum allowable concentration of I-131 in the plant vent
- AF = The allocation factor for the plant vent for one unit from Table 6.2
- SF = A safety factor to insure that the dose rate limits of the radiological effluent controls are not exceeded (0.9).
- f_{I-131} = fraction of the total non-noble gas concentration that is due to I-131. Defined as:

$$f_{I-131} = \frac{C_{I-131}}{\sum_i C_i} \quad (22)$$

PACIFIC GAS AND ELECTRIC COMPANY
DIABLO CANYON POWER PLANT

NUMBER CAP A-8
REVISION 26
PAGE 24 OF 62
UNITS 1 AND 2

TITLE: Off-Site Dose Calculations

1500 = (mrem/yr) the site organ dose rate limit for Iodine-131, for Iodine-133, for tritium, and for all radioactive materials in particulate form with half-lives greater than 8 days.

472 = the conversion constant to cc/sec from cfm

F_{pv} = total flowrate in the plant vent, in cfm (maximum plant vent flowrate is 263,000 cfm)

$(\overline{\chi/Q})_{Max}$ = maximum historical site boundary dispersion factor, based on 5 year averages derived from the meteorological database, from Table 10.2.

P_i^w = Inhalation dose factor for nuclide "i" (mrem/yr/ $\mu\text{Ci}/\text{m}^3$) for child age group for worst case organ, from Table 10.4. Dose factors are based upon NUREG 0133 methodology. Inhalation dose conversion factors are taken from Reg. Guide 1.109, Rev 1, Table E-9, with the following exceptions: H-3, Sb-124 and Sb-125 inhalation dose conversion factors taken from NUREG/CR-4013.

f_i = fraction of total non-noble gas concentration (excluding tritium) that is due to nuclide, i, and defined as:

$$f_i = \frac{C_i}{\sum_i C_i} \quad (23)$$

PACIFIC GAS AND ELECTRIC COMPANY
 DIABLO CANYON POWER PLANT

NUMBER CAP A-8
 REVISION 26
 PAGE 25 OF 62
 UNITS 1 AND 2

TITLE: Off-Site Dose Calculations

4. PLANT VENT PARTICULATE MONITOR - RE-28

The Plant Vent Particulate concentration is monitored by rad monitor RE-28. The alarm setpoint methodology is based upon the assumption of a 5% cross talk from the iodine channel. This is due to the retention of a small portion of iodine on the particulate filter.

A release mixture based upon the RCS source term is also assumed.

The High Alarm Set Point methodology for RE-28 is given by Equation 24.

$$\begin{aligned}
 {}^{28\text{Max}}C_T(\text{Particulates}) = & AF \times SF \times \left(0.05 \times \sum_{\text{Iodines}} f_{\text{Iodines}} + \sum_{\text{Particulates}} f_{\text{Particulates}} \right) \\
 & \times \frac{1500}{472 \times F_{pv} \times (\chi/Q)_{\text{Max}} \sum_i P_i^w f_i} \qquad (24)
 \end{aligned}$$

Where:

- ${}^{28\text{Max}}C_T(\text{Particulate})$ = Maximum allowable particulate concentration in the plant vent
- AF = The allocation factor for the plant vent for one unit from Table 6.2
- SF = A safety factor to insure that the dose rate limits of the radiological effluent controls are not exceeded (0.9).
- 0.05 = Fraction of total iodine activity retained on particulate filter.
- f_{Iodines} = Fraction of the total non-noble gas concentration that is due to iodines.
- $f_{\text{Particulates}}$ = Fraction of the total non-noble gas concentration that is due to particulates.
- 1500 = (mrem/yr) the site organ dose rate limit for Iodine-131, for Iodine-133, for tritium, and for all radioactive materials in particulate form with half-lives greater than 8 days.
- 472 = Conversion constant to cc/sec from cfm
- F_{pv} = Total flowrate in the plant vent, in cfm (maximum plant vent flowrate is 263,000 cfm)

PACIFIC GAS AND ELECTRIC COMPANY
DIABLO CANYON POWER PLANT

NUMBER CAP A-8
REVISION 26
PAGE 26 OF 62
UNITS 1 AND 2

TITLE: Off-Site Dose Calculations

$(\overline{\chi/Q})_{Max}$ = Maximum historical site boundary dispersion factor, based on 5 year averages derived from the meteorological database, from Table 10.2

P_i^w = Inhalation dose factor for nuclide "i" (mrem/yr/ $\mu\text{Ci}/\text{m}^3$) for child age group for worst case organ, from Table 10.4. Dose factors are based upon NUREG 0133 methodology. Inhalation dose conversion factors are taken from Reg. Guide 1.109, Rev 1, Table E-9, with the following exceptions: H-3, Sb-124 and Sb-125 inhalation dose conversion factors taken from NUREG/CR-4013.

f_i = Fraction of total non-noble gas concentration (excluding tritium) that is due to nuclide, i, as defined by Equation 23.

PACIFIC GAS AND ELECTRIC COMPANY
DIABLO CANYON POWER PLANT

NUMBER CAP A-8
REVISION 26
PAGE 27 OF 62
UNITS 1 AND 2

TITLE: Off-Site Dose Calculations

5. WASTE GAS DECAY TANK MONITOR - RE-22 HASP

Effluent releases from the Waste Gas Decay Tank are monitored by rad monitor RE-22. RE-22 provides alarm and automatic release termination functions.

The High Alarm Set Point methodology for RE-22 is given by Equation 25, which is based upon the assumption that the skin dose rate limit is most limiting.

$${}^{22\text{Max}}C_T(NG) = AF \times SF \times \frac{3000}{472 \times F_{gdt} \times (\overline{\chi/Q})_{Max} \times 1.34 \times 10^3} \quad (25)$$

Where:

- ${}^{22\text{Max}}C_T(NG)$ = the maximum allowable total concentration of noble gas in the gas decay tank exhaust line, in $\mu\text{Ci/cc}$
- AF = the allocation factor for the waste gas decay tank for one unit from Table 6.2
- SF = safety factor to ensure that dose rate limits of the radiological effluent controls are not exceeded (0.9)
- 3000 = (mrem/yr) the site Skin dose rate limit for instantaneous releases
- 472 = the conversion constant to cc/sec from cfm
- F_{gdt} = maximum flow rate for the gas decay tank system (31 cfm)
- $(\overline{\chi/Q})_{Max}$ = the maximum historical site boundary dispersion factor, based on 5 year averages derived from the meteorological data base from Table 10.2.
- 1.34×10^3 = the skin dose factor for Kr-85 (mrem/yr/ $\mu\text{Ci/m}^3$, from Table 10.3.

PACIFIC GAS AND ELECTRIC COMPANY
 DIABLO CANYON POWER PLANT

NUMBER CAP A-8
 REVISION 26
 PAGE 28 OF 62
 UNITS 1 AND 2

TITLE: Off-Site Dose Calculations

6. CONTAINMENT PURGE - RE-44 HASP

The Containment Purge is monitored by rad monitor RE-44. RE-44 provides alarm and automatic release termination functions.

The HASP for RE-44 must limit the noble gas dose rate for skin and total body exposure. In order to address this, two set points are calculated. One set point is calculated based upon limiting the total body dose rate and the other limits the skin dose rate. The more limiting set point is used. The High Alarm Set Point methodology for RE-44 is given by Equations 26 and 27.

a) Limiting Concentration Based on Total Body Dose

$${}^{44A/BMax}C_T(NG) = AF \times SF \times \frac{500}{472 \times F_{ct} \times (\chi/Q)_{Max} \times \sum K_i f_i} \quad (26)$$

Where:

- ${}^{44A/BMax}C_T(NG)$ = the maximum allowable total concentration of noble gas in the containment purge exhaust line, in $\mu\text{Ci/cc}$
- AF = the allocation factor for the containment purge for one unit from Table 6.2
- SF = safety factor to ensure that dose rate limits of radiological effluent controls are not exceeded (0.9)
- 500 = (mrem/yr) the site Total Body dose rate limit for instantaneous releases
- 472 = the conversion constant to cc/sec from cfm
- F_{ct} = maximum flow rate in the containment purge system (maximum containment purge flowrate is 55,000 cfm)
- $(\chi/Q)_{Max}$ = the maximum historical site boundary dispersion factor, based on 5 year averages derived from the meteorological data base averages, from Table 10.2.

PACIFIC GAS AND ELECTRIC COMPANY
 DIABLO CANYON POWER PLANT

NUMBER CAP A-8
 REVISION 26
 PAGE 29 OF 62
 UNITS 1 AND 2

TITLE: Off-Site Dose Calculations

K_i = whole body dose factor (mrem/yr/ $\mu\text{Ci}/\text{m}^3$) for isotope "i." Dose factors are presented in Table 10.3.

f_i = the fraction of the concentration of the individual noble gas radionuclide, "i," in the total mix of noble gas effluents in the containment purge line.

b) Limiting Concentration Based on Skin Dose

Skin dose should be calculated whenever an RCS sample contains a significant fraction of Kr-85.

The concentration limit calculated by this method should then be compared to the concentration limit calculated for total body dose. The smaller concentration should be selected as the limiting concentration for the HASP.

$${}^{44\text{A}/\text{BMax}}C_T(\text{NG}) = AF \times SF \times \frac{3000}{472 \times F_{ct} \times (\chi/Q)_{\text{Max}} \times \sum_i (L_i + 1.1M_i) f_i} \quad (27)$$

Where:

${}^{44\text{A}/\text{BMax}}C_T(\text{NG})$ = the maximum allowable total concentration of noble gas in the plant vent in $\mu\text{Ci}/\text{cc}$

AF = the allocation factor for the containment purge for one unit from Table 6.2

SF = safety factor to ensure that dose rate limits of the radiological effluent controls are not exceeded (0.9)

3000 = (mrem/yr) the site skin dose rate limit for instantaneous releases.

472 = the conversion constant to cc/sec from cfm

F_{ct} = total flow rate in the containment purge system, in cfm (maximum containment purge flow rate is 55,000 cfm)

$(\chi/Q)_{\text{Max}}$ = the maximum historical site boundary dispersion factor, based on 5 year averages derived from the meteorological data base averages, from Table 10.2.

PACIFIC GAS AND ELECTRIC COMPANY
DIABLO CANYON POWER PLANT

NUMBER CAP A-8
REVISION 26
PAGE 30 OF 62
UNITS 1 AND 2

TITLE: Off-Site Dose Calculations

- L_i = the skin dose factor (mrem/yr per $\mu\text{Ci}/\text{m}^3$) for isotope "i." Dose factors are presented in Table 10.3.
- 1.1 = Conversion factor mrem/mrad. Converts air dose to skin dose.
- M_i = the gamma air dose factor (mrad/yr per $\mu\text{Ci}/\text{m}^3$) for isotope "i." Dose factors are presented in Table 10.3.
- f_i = the fraction of the concentration of the individual noble gas radionuclide, "i," in the total mix of noble gas effluents in the containment purge line.

c. Mode 6 Particulate activity.

The HASP calculation specified in this section based upon Noble Gas effluent limitations conservatively bounds the Tech. Spec. requirement for particulate activity in Mode 6. The FSAR expected case accident for Mode 6 is a containment fuel handling accident which does not include a particulate release. Therefore, the HASP for RM-44 in this section conservatively satisfies the Tech. Spec. (Ref.: 8.15)

PACIFIC GAS AND ELECTRIC COMPANY
DIABLO CANYON POWER PLANT

NUMBER CAP A-8
REVISION 26
PAGE 31 OF 62
UNITS 1 AND 2

TITLE: Off-Site Dose Calculations

6.2.3 Gaseous Dose Rate Calculation Methodology

a. Total Body Noble Gas Dose Rate Methodology

The dose rate to the total body due to immersion in a cloud of noble gases is given by:

$$\left(\overline{\chi/Q}\right)_{Max} \sum_i K_i \dot{Q}_i \leq 500 \text{ mrem/year} \quad (28)$$

Where:

\dot{Q}_i = The release rate of radionuclide i in units of $\mu\text{Ci/sec}$.

All other terms are as previously defined.

b. Skin Dose Rate Methodology

The dose rate to the skin due to immersion in a cloud of noble gases is given by:

$$\left(\overline{\chi/Q}\right)_{Max} \sum_i (L_i + 1.1M_i) \dot{Q}_i \leq 3000 \text{ mrem/year} \quad (29)$$

Where the terms are as previously defined.

PACIFIC GAS AND ELECTRIC COMPANY
 DIABLO CANYON POWER PLANT

NUMBER CAP A-8
 REVISION 26
 PAGE 32 OF 62
 UNITS 1 AND 2

TITLE: Off-Site Dose Calculations

c. Radioiodine, Tritium and Particulate Dose Rate Methodology

The dose rate to organ, o, due to radioiodines, tritium and particulates released in gaseous effluents is given by:

$$\left(\overline{\chi/Q}\right)_{Max} \sum_i P_{io} \dot{Q}_i \leq 1500 \text{ mrem/year} \quad (30)$$

Where:

$$P_{io} = K'(BR)DFA_{io}$$

and

$$K' = 10^6 \text{ } \rho\text{Ci}/\mu\text{Ci}$$

BR = The breathing rate of the a child age group in m³/yr. The default value of 3700 m³/yr is taken from Table E-5 of Reg. Guide 1.109.

DFA_i = The inhalation dose factor for organ o, for the child age group for radionuclide, i, from Table E-9 of Reg. Guide 1.109 in mrem/ρCi, with the following exceptions: H-3, Sb-124 and Sb-125 inhalation dose conversion factors taken from NUREG/CR4013.

All other terms are as previously defined.

Values for P_{io} are listed in Table 10.6.

PACIFIC GAS AND ELECTRIC COMPANY
 DIABLO CANYON POWER PLANT

NUMBER CAP A-8
 REVISION 26
 PAGE 33 OF 62
 UNITS 1 AND 2

TITLE: Off-Site Dose Calculations

6.2.4 Noble Gas Air Dose Calculation Methodology

a. Gamma Air Dose

The gamma air dose due to immersion in a cloud of noble gases is given by:

$$D_{ay} = 3.17 \times 10^{-8} (\overline{\chi/Q})_{Max} \sum_1 M_i \tilde{Q}_i \quad (31)$$

Where:

D_{ay} = Gamma air dose in mrad.

3.17×10^{-8} = Conversion constant yr/sec.

M_i = Gamma air dose factor for nuclide i, in mrad/yr per $\mu\text{Ci}/\text{m}^3$. Values are listed in Table 10.3.

\tilde{Q}_i = Total release of noble gas radionuclide, i, in μCi .

All other terms are as previously defined.

b. Beta Air Dose

The beta air dose due to immersion in a cloud of noble gases is given by:

$$D_{a\beta} = 3.17 \times 10^{-8} (\overline{\chi/Q})_{Max} \sum_1 N_i \tilde{Q}_i \quad (32)$$

Where:

$D_{a\beta}$ = Beta air dose in mrad.

N_i = Beta air dose factor for nuclide i, in mrad/yr per $\mu\text{Ci}/\text{m}^3$. Values are listed in Table 10.3.

All other terms are as previously defined.

**PACIFIC GAS AND ELECTRIC COMPANY
DIABLO CANYON POWER PLANT**

**NUMBER CAP A-8
REVISION 26
PAGE 34 OF 62
UNITS 1 AND 2**

TITLE: Off-Site Dose Calculations

6.2.5 Dose To Critical Receptor Due To Radioiodines, Tritium and Particulates Released in Gaseous Effluents

a. Calculation Methodology

The dose to an individual (critical receptor) due to radioiodines, tritium and particulates released in gaseous effluents with half-lives greater than 8 days is determined based upon the methodology described in NUREG 0133. This methodology makes use of the maximum individual concept described in Regulatory Guide 1.109. The maximum individual is characterized as maximum with regard to food consumption, occupancy, and other usage parameters. This concept therefore models those individuals within the local population with habits representing reasonable deviations from the average. In all physiological and metabolic respects, the maximum individual is assumed to have those characteristics that represent the average for the age group of interest.

The concept of critical receptor is introduced as a further refinement of the maximum individual. The critical receptor is defined as that individual that receives the largest dose based upon the combination of dose pathways that have been shown to actually exist. The critical receptor concept is applied at that location where the combination of dispersion (χ/Q), deposition (D/Q), existing pathways, occupancy time, receptor age group, and effluent source term indicates the maximum potential exposure. The inhalation and ground plane exposure pathways are considered to exist at all locations. The grass-cow-milk, grass-cow-meat, and vegetation pathways are considered based on their actual existence in the vicinity of the plant.

The dose pathways that have been shown to actually exist at DCPP are the ground plane, inhalation and the vegetation pathways. These dose pathways are reviewed yearly and updated based upon the annual land use census survey in order to insure that actual exposure to an individual will not be substantially underestimated.

The locations of the pathways and descriptions are listed in Table 10.2.

PACIFIC GAS AND ELECTRIC COMPANY
DIABLO CANYON POWER PLANT

NUMBER CAP A-8
REVISION 26
PAGE 35 OF 62
UNITS 1 AND 2

TITLE: Off-Site Dose Calculations

b. Dose Calculation

The dose contributions to the total body and each individual organ (bone, liver, thyroid, kidney, lung and GI-LLI) of the maximum exposed individual (Critical Receptor) due to radioactive gaseous effluent releases is calculated for all radionuclides identified in gaseous effluents released to unrestricted areas using the following expression:

$$D_{apo} = 3.17 \times 10^{-8} \bar{W}_{CR} \sum_i R_{aipo} \tilde{Q}_i \quad (33)$$

Where:

D_{apo} = Dose to the critical receptor for age group a, pathway p, and organ o, in mrem.

\bar{W}_{CR} = Critical receptor $\bar{\chi}/\bar{Q}$ for immersion, inhalation and all tritium pathways (seconds/m³) from Table 10.2.

= Critical receptor \bar{D}/\bar{Q} for ground plane and all ingestion pathways (1/m²) from Table 10.2.

R_{aipo} = Site specific dose factor for age group a, radionuclide i, pathway p, and organ j (mrem/yr per $\mu\text{Ci}/\text{m}^3$ for inhalation and tritium pathways - mrem/yr per $\mu\text{Ci}/(\text{sec m}^2)$ for ground plane and ingestion pathways). These dose factors are listed in Table 10.6.

The site specific dose factors are calculated based upon NUREG 0133 methodology. All dose conversion factors are taken from Reg. Guide 1.109, Rev 1, Tables E6-E14, with the following exceptions: H-3, Sb-124 and Sb-125 dose conversion factors taken from NUREG/CR-4013.

\tilde{Q}_i = The total release of radionuclide i, in units of μCi .

PACIFIC GAS AND ELECTRIC COMPANY
DIABLO CANYON POWER PLANT

NUMBER CAP A-8
REVISION 26
PAGE 36 OF 62
UNITS 1 AND 2

TITLE: Off-Site Dose Calculations

6.2.6 Noble Gas Gaseous Radioactive Waste (GRW) Batch Release Percent Release Rate Limits (PRRLs) and Expected Reading (ER)

The Percent Release Rate Limit (PRRL) for noble gas releases for each unit is calculated based upon the 500 mrem/yr whole body dose rate limit, and is given by Equation 34.

$$PRRL = \frac{(\overline{\chi/Q})_{Max} \sum_i K_i \dot{Q}_i}{(0.48)(500mrem/yr)} \times 100\% \quad (34)$$

Where:

$(\overline{\chi/Q})_{Max}$ = The maximum site boundary dispersion factor based on 5 year averages from Table 10.2.

K_i = Whole body dose factor (mrem/yr per $\mu\text{Ci}/\text{m}^3$) for isotope "i." Dose factors are presented in Table 10.3.

\dot{Q}_i = Total release rate of isotope "i" from all sources discharged through this release point in $\mu\text{Ci}/\text{sec}$.

0.48 = Plant vent allocation factor for one unit from Table 6.2.

500 mrem/yr = Site noble gas dose rate limit.

PACIFIC GAS AND ELECTRIC COMPANY
 DIABLO CANYON POWER PLANT

NUMBER CAP A-8
 REVISION 26
 PAGE 37 OF 62
 UNITS 1 AND 2

TITLE: Off-Site Dose Calculations

The Expected Reading (ER) is the anticipated monitor response based upon the known plant vent concentration and the monitor response factors. The Expected Readings for RE-22, RE-44, RE-14 are given by Equations 35, 36, and 37.

$$ER_{(RE-22)} = BKG_{(RE-22)} + \sum_i k_{(RE-22),i} C_{(RE-22),i} \quad (35)$$

Where:

- ER_(RE-22) = Expected reading on monitor RE-22 in μCi/cc.
- BKG_(RE-22) = Monitor background.
- k_{(RE-22),i} = Noble gas monitor response factor for nuclide "i" for monitor RE-22.
- C_{(RE-22),i} = Concentration of nuclide "i" seen by RE-22.

$$ER_{(RE-44)} = BKG_{(RE-44)} + CCSP_{(RE-44)} \sum_i k_{(RE-44),i} C_{(RE-44),i} \quad (36)$$

Where:

- ER_(RE-44) = Expected reading on monitor RE-44 in μCi/cc.
- BKG_(RE-44) = Monitor background.
- CCSP_(RE-44) = Conversion constant setpoint for monitor RE-44.
- k_{(RE-44),i} = Noble gas monitor response factor for nuclide "i" for monitor RE-44.
- C_{(RE-44),i} = Concentration of nuclide "i" seen by monitor RE-44.

$$ER_{(RE-14)} = BKG_{(RE-14)} + CCSP_{(RE-14)} \sum_i k_{(RE-14),i} C_{(RE-14),i} \quad (37)$$

Where:

- ER_(RE-14) = Expected reading on monitor RE-14 in μCi/cc.
- BKG_(RE-14) = Monitor background.
- CCSP_(RE-14) = Conversion constant setpoint for monitor RE-14.

PACIFIC GAS AND ELECTRIC COMPANY
 DIABLO CANYON POWER PLANT

NUMBER CAP A-8
 REVISION 26
 PAGE 38 OF 62
 UNITS 1 AND 2

TITLE: Off-Site Dose Calculations

$k_{(RE-14)_i}$ = Noble gas monitor response factor for nuclide "i" for monitor RE-14.

$C_{(RE-14)_i}$ = Concentration of nuclide "i" seen by monitor RE-14.

Generally if the Expected Reading (ER) is greater than the existing HASP setting (an "administrative limit" as set by CY2.DC1) then no release should be made until a calculation shows that the HASP (Admin Limit) can be raised so the release can be legally discharged. On the other hand should the ER be less than the existing HASP (Admin Limit), then the release can be discharged.

6.2.7 IPT - PRRL

The Percent Release Rate Limit (PRRL) for radioiodines, tritium and particulates for each unit is calculated based upon the 1500 mrem/yr organ dose rate limit. The dose rate is calculated for the inhalation pathway to the child age group using the highest (worst case) organ dose factor for nuclide. The Percent Release Rate Limit based on the worst case organ is given by Equation 38.

$$PRRL_o = \frac{(\overline{\chi/Q})_{Max} \sum_i P_i^w \dot{Q}_i}{(0.48)(1500mrem/yr)} \times 100\% \quad (38)$$

Where:

$(\overline{\chi/Q})_{Max}$ = The maximum site boundary dispersion factor based on 5 year averages from Table 10.2.

P_i^w = Inhalation dose factor for nuclide "i" (mrem/yr/ μ Ci/ m^3) for child age group for worst case organ, from Table 10.4. Dose factors are based upon NUREG 0133 methodology. Inhalation dose conversion factors are taken from Reg. Guide 1.109, Rev 1, Table E-9, with the following exceptions: H-3, Sb-124 and Sb-125 inhalation dose conversion factors taken from NUREG/CR-4013.

\dot{Q}_i = Release rate of isotope "i" in μ Ci/sec.

0.48 = Plant vent location factor for one unit from Table 6.2.

1500 mrem/yr = Site radioiodine, tritium and particulate dose rate limit.

**PACIFIC GAS AND ELECTRIC COMPANY
DIABLO CANYON POWER PLANT**

**NUMBER CAP A-8
REVISION 26
PAGE 39 OF 62
UNITS 1 AND 2**

TITLE: Off-Site Dose Calculations

6.2.8 Alternate Dose Methodologies

For purposes of routine gaseous effluent dose assessment, the methodology of NUREG 0133 (described in Section 6.2.5) will be used. However, DCCP may elect to utilize the dose methodologies of Regulatory Guide 1.109 or the GASPAR computer code for special purposes such as evaluation of potential new gaseous effluent dose pathways or critical receptors.

6.2.9 Gas Effluent Dose Projection

The projected dose contributions from each reactor unit due to gaseous effluents for the current calendar month, quarter and current calendar year must be determined in accordance with the methodology and parameters in the ODCP at least every 31 days.

The computer program, Radioactive Effluent Management System (REMS), is used for this projection. Therefore, by the first day of the year, the following tables in REMS need to be updated:

- GRW dose receptor
- GRW dose rate receptor
- GRW external dose select
- GRW external occupancy
- GRW internal dose select
- GRW internal occupancy

The purpose of this is to determine if appropriate treatment of gaseous radioactive materials in relation to maintaining releases "as low as reasonably achievable," is necessary.

Projections will be made, at least by the end of each month with attention to the frequency requirement contained in radiological effluent controls program.

The projected dose from each reactor unit is given by:

$$D_p = D_{p,U} + \frac{1}{2} D_{p,Com} \tag{39}$$

Where:

D_p = Projected Dose.

$D_{p,U}$ = Projected dose attributed to reactor unit, U.

$D_{p,Com}$ = Projected dose common to both reactor units.

PACIFIC GAS AND ELECTRIC COMPANY
DIABLO CANYON POWER PLANT

NUMBER CAP A-8
REVISION 26
PAGE 40 OF 62
UNITS 1 AND 2

TITLE: Off-Site Dose Calculations

The 31 day projected dose is calculated by Equation 40.

$$D_P^M = 31 \times \frac{D_A^{PM} + d_A^{CM} + d_P^{CB}}{(T + t)} \quad (40)$$

Where:

D_P^M = Projected Dose for the next 31 day period.

D_A^{PM} = Previous Month's Actual Dose

d_A^{CM} = Current Month Actual Dose to date

d_P^{CB} = Projected Dose from Current Batch Release

T = Number of days in the previous month

t = Number of days into the present month

Projected quarterly doses are determined by Equation 41.

$$D_P^{CQ} = d_A^{CQ} + (92 - t) \frac{D_A^{PQ} + d_A^{CQ} + d_P^{CB}}{(T + t)} \quad (41)$$

Where:

D_P^{CQ} = Projected dose for the current calendar quarter.

d_A^{CQ} = Current quarter to date actual dose.

D_A^{PQ} = Previous quarter's actual dose.

d_P^{CB} = Projected dose as a result of the current batch release.

T = Number of days in the previous quarter.

t = Number of days into the present quarter.

PACIFIC GAS AND ELECTRIC COMPANY
DIABLO CANYON POWER PLANT

NUMBER CAP A-8
REVISION 26
PAGE 41 OF 62
UNITS 1 AND 2

TITLE: Off-Site Dose Calculations

Projected yearly doses are determined by Equation 42.

$$D_P^{CY} = d_A^{CY} + (366 - t) \frac{D_A^{PY} + d_A^{CY} + d_P^{CB}}{(T + t)} \quad (42)$$

Where:

- D_P^{CY} = Projected dose for the current calendar year.
- d_A^{CY} = Current year to date actual dose.
- D_A^{PY} = Previous year's actual dose.
- d_P^{CB} = Projected dose as a result of the current batch release.
- T = Number of days in the previous year.
- t = Number of days into the present year.

6.2.10 Unplanned Gaseous Releases (Abnormal Releases)

- a. An unplanned release is an unexpected and potentially unmonitored release to the environment due to operational error or equipment malfunctions.
 1. Unmonitored unplanned releases shall have a report written by the Radiochemistry Effluents Engineer describing the event with a calculation, if possible, of the percent of RECP limit. This will then be forwarded to PSRC for review. Describe these unplanned releases in the Annual Radioactive Effluent Release Report.
 2. Monitored unplanned releases which exceed 1% of the RECP limit will also have a report written describing the event and must be forwarded to the PSRC for review. Describe these unplanned releases in the Annual Radioactive Effluent Release Report. For purposes of classification only, unplanned release puffs through the plant vent may use one hour integrated resolution times.

PACIFIC GAS AND ELECTRIC COMPANY
DIABLO CANYON POWER PLANT

NUMBER CAP A-8
REVISION 26
PAGE 42 OF 62
UNITS 1 AND 2

TITLE: Off-Site Dose Calculations

6.3 40 CFR 190 Dose Calculations

6.3.1 Pathways

Calculation of total uranium fuel cycle dose for purposes of demonstrating compliance with 40 CFR 190 requires the contributions from liquid and gaseous effluent as well as direct radiation from the units and outside storage tanks to be considered. The total uranium fuel cycle dose to any member of the public will be calculated by summing the following doses:

- Direct Radiation Dose
- Liquid Effluent Dose
- Noble Gas Dose
- Radioiodine, Tritium and Particulate Gaseous Effluent Dose

6.3.2 Methodology

a. Direct Radiation Dose

Determination of direct radiation dose from the reactor units and from outside storage tanks may be made by direct survey measurements, derived from environmental TLD data, or calculated by shielding code.

The direct radiation dose will also take into account residence times near the site based upon land use census information.

The direct radiation determination using environmental TLD is given by equation 43.

$$D'_{s.b.} = \left[\frac{r_{adj}}{800} \right]^2 D'_{r_0} \times (9.57) \times e^{-(6.38)} \quad (43)$$

where:

$D'_{s.b.}$ = the dose rate at the site boundary, in mrem

D'_{r_0} = the dose rate from the dosimetry reading, in mrem

r_{adj} = the distance from the point source to the dosimetry, in meter

800 = the distance from the point source to site boundary, in meter

PACIFIC GAS AND ELECTRIC COMPANY
 DIABLO CANYON POWER PLANT

NUMBER CAP A-8
 REVISION 26
 PAGE 43 OF 62
 UNITS 1 AND 2

TITLE: Off-Site Dose Calculations

b. Noble Gas Dose

The noble gas skin dose and total body dose contributions to the total uranium fuel cycle dose to a member of the public will be determined as shown in Equations 44 and 45.

$$\text{Noble Gas Total Body Dose} = 3.17 \times 10^{-8} (\overline{\chi/Q})_R \sum_i K_i \tilde{Q}_i \quad (44)$$

$$\text{Noble Gas Skin Dose} = 3.17 \times 10^{-8} (\overline{\chi/Q})_R \sum_i (L_i + 1.1 M_i) \tilde{Q}_i \quad (45)$$

Where:

3.17×10^{-8} = Conversion constant yr/sec.

$(\overline{\chi/Q})_R$ = Maximum historical dispersion factor for receptor of interest, based on 5 year averages from Table 10.2.

K_i = Whole body dose factor for nuclide i , in mrem/yr per $\mu\text{Ci}/\text{m}^3$. Values are listed in Table 6.3.

L_i = Skin dose factor for nuclide i , in mrem/yr per $\mu\text{Ci}/\text{m}^3$. Values are listed in Table 6.3.

1.1 = Conversion factor mrem/mrad. Converts air dose to skin dose.

M_i = Gamma air dose factor for nuclide i , in mrad/yr per $\mu\text{Ci}/\text{m}^3$. Values are listed in Table 10.3.

\tilde{Q}_i = Total release of noble gas radionuclide, i , in $\mu\text{Ci}/\text{sec}$.

PACIFIC GAS AND ELECTRIC COMPANY
DIABLO CANYON POWER PLANT

NUMBER CAP A-8
REVISION 26
PAGE 44 OF 62
UNITS 1 AND 2

TITLE: Off-Site Dose Calculations

c. Liquid and Gaseous Effluent Dose

The doses from liquid effluents and radioiodines, tritium and particulates in gaseous effluents will be determined by Equations 1 and 33, respectively.

For purposes of calculating the dose required by the radiological effluent controls, more realistic assumptions concerning the liquid and gaseous effluent dose pathways will be used, based upon the most recent land use census data as well as the latest environmental monitoring information.

These assumptions may include, but not be limited to: more realistic liquid dilution factors, location and age of actual individuals, site specific food pathway parameters, and documentation of true food consumption. Other assumptions may be used provided they can be substantiated by census or direct measurement.

PACIFIC GAS AND ELECTRIC COMPANY
 DIABLO CANYON POWER PLANT

NUMBER CAP A-8
 REVISION 26
 PAGE 45 OF 62
 UNITS 1 AND 2

TITLE: Off-Site Dose Calculations

6.4 On-Site Dose to Members of the Public

Members of the public are occasionally granted access within the site boundary, but only in the owner controlled area up to the protected area boundary. The most common public access activities are: tours to the simulator (training building) or Bio Lab, policemen using the shooting range (most frequent activity), cattle drives through to adjacent properties, and visits of American Indians to on-site burial grounds (closest to the plant).

Exposure to members of the public due to liquid releases while on-site is highly unlikely and therefore not addressed. Exposure due to gaseous releases and direct radiation are credible and therefore are considered.

The dose to members of the public during on-site activities will be primarily determined by the duration of the on-site visitation time and by the closest proximity to the plant.

For gaseous releases the doses are calculated using Equations 44, 45 and 33. The R_i 's in Equation 33 consider only the inhalation and ground plane pathway and exclude the infant age group.

The X/Q and D/Q values are modified using logarithmic extrapolation from the site boundary to the on-site location of interest as shown in Equations 46 and 47.

$$\log[X/Q]_{on-site} \approx \frac{\log[X/Q]_{S.B.} - \log[X/Q]_{loc.}}{\log(dist.S.B.) - \log(dist.loc.)} [\log(dist.on - site) - \log(dist.S.B.)] + \log[X/Q]_{S.B.} \quad (46)$$

$$\log[D/Q]_{on-site} \approx \frac{\log[D/Q]_{S.B.} - \log[D/Q]_{loc.}}{\log(dist.S.B.) - \log(dist.loc.)} [\log(dist.on - site) - \log(dist.S.B.)] + \log[D/Q]_{S.B.} \quad (47)$$

Based upon Regulatory Guide 1.111, these equations can be expected to provide reasonable dispersion and deposition estimates for distances as close as 200 meters.

Determination of direct radiation dose from the reactor units and from outside storage tanks may be made by direct survey measurements, derived from environmental TLD data, or calculated by shielding code.

A distance of 200 meters from the plant (both units) equidistant from the plant vent is arbitrarily selected as the closest perimeter for which on-site doses will be calculated.

PACIFIC GAS AND ELECTRIC COMPANY
 DIABLO CANYON POWER PLANT

NUMBER CAP A-8
 REVISION 26
 PAGE 46 OF 62
 UNITS 1 AND 2

TITLE: Off-Site Dose Calculations

The activities of the members-of-the-public while on-site (described above), are at or beyond 200 meters. Table 6.3 details the types of on-site activities that members-of-the-public might be expected to participate in at DCP. The sectors and closest distances in which they may visit as well as expected visitation duration are also shown (based on Security Section information).

Table 6.3

Expected On-Site Distances and Visitation Times for Members of the Public

ONSITE MEMBER OF THE PUBLIC	SECTOR OF VISITATION	CLOSEST POINT OF APPROACH TO PLANT	AVERAGE EXPECTED VISITATION TIME PER YEAR
Police at shooting range	SE	700m	208 hours
Tour Participants			
Simulator Bldg	S (SE)	310m	4 hours
Bio Lab	SSE (SE)	460m	6 hours
Overlook	E	210m	1 hours
American Indians at burial grounds	NW NNW	200m 200m	96 hours 96 hours
Ranch hands driving cattle around site	NW NNW N NNE NE	250m 350m 320m 450m 630m	1 hour 1 hour 1 hour 1 hour 1 hour

PACIFIC GAS AND ELECTRIC COMPANY
DIABLO CANYON POWER PLANT

NUMBER CAP A-8
REVISION 26
PAGE 47 OF 62
UNITS 1 AND 2

TITLE: Off-Site Dose Calculations

7. ACCEPTANCE CRITERIA

7.1 There is no quantitative acceptance for this procedure. If the task or analysis has been accomplished within the bounds of this procedure, it is considered acceptable.

8. REFERENCES

- 8.1 Draft Radiological Tech Specs for PWRs, NUREG No. 0472, May 1978.
- 8.2 Calculation of Annual Doses to Man From Routine Releases of Reactor Effluents for the Purpose of Evaluating Compliance with 10 CFR 50, Appendix I, Regulatory Guide 1.109, Rev. 0, March 1976.
- 8.3 Calculation of Annual Doses to Man From Routine Releases of Reactor Effluents for the Purpose of Evaluating Compliance with 10 CFR 50, Appendix I, Regulatory Guide 1.109, Rev. 1, October 1977.
- 8.4 Preparation of Radiological Effluent Tech Specs for Nuclear Power Plants, NUREG No. 0133, October 1978.
- 8.5 LADTAP II - Technical Reference and User Guide, NUREG/CR-4013.
- 8.6 Methods for Demonstrating LWR Compliance with the EPA Uranium Fuel Cycle Standard 40 CFR 190, NUREG No. 0543, January 1980.
- 8.7 Methods for Estimating Atmospheric Transport and Dispersion of Gaseous Effluents in Routine Releases from Light-Water-Cooled Reactors, Regulatory Guide, 1.111, Rev. 1, July, 1977.
- 8.8 Radioactive Decay Data Tables, David C. Kocher. DOE/TIC-11026, 1981.
- 8.9 CAP A-6, "Gaseous Radwaste Discharge Management."
- 8.10 CAP A-5, "Liquid Radwaste Discharge Management."
- 8.11 CAP D-15, "Steam Generator Leak Rate Determination."
- 8.12 CAP D-19, "Correlation of Rad Monitors to Radioactivity."
- 8.13 CY2.DC1, "Radiation Monitoring System High Alarm Setpoint Control Procedure."
- 8.14 CY2.ID1, "Radiological Effluent and Controls Program" (RECP)
- 8.15 "Setpoint Calculation for Containment Ventilation Exhaust Monitor," Calc # NSP-1&2-39-44, 10/92 and 11/92 and AR A0430610.
- 8.16 NUREG 2919, Computer Code XOQDOQ, Revision 2, September, 1982.

9. RECORDS

9.1 Data Sheets and records will be maintained in the Records Management System (RMS) in accordance with CY1.DC1, "Analytical Data Processing Responsibilities."

PACIFIC GAS AND ELECTRIC COMPANY
DIABLO CANYON POWER PLANT

NUMBER CAP A-8
REVISION 26
PAGE 48 OF 62
UNITS 1 AND 2

TITLE: Off-Site Dose Calculations

10. APPENDICES

10.1 Tables

11. ATTACHMENTS

11.1 "Liquid Discharges (LRW) Monitored for Radioactivity," 10/04/00

11.2 "Gaseous Releases (GRW) Monitored for Radioactivity," 10/31/00

12. SPONSOR

John Knemeyer

PACIFIC GAS AND ELECTRIC COMPANY
 DIABLO CANYON POWER PLANT

NUMBER CAP A-8
 REVISION 26
 PAGE 49 OF 62
 UNITS 1 AND 2

TITLE: Off-Site Dose Calculations

TABLE 10.1
LRW COMPOSITE DOSE FACTORS¹, A_o,
FOR ADULTS AT A SALTWATER SITE
 (mrem/hour per μ Ci/ml)
 organ "o"

Nuclide	Tot Body	Thyroid	Kidney	Lung	GI-LLI	Bone	Liver
H-3	1.61E-01	1.61E-01	1.61E-01	1.61E-01	1.61E-01	0.00E+00	1.61E-01
Na-24	4.57E-01	4.57E-01	4.57E-01	4.57E-01	4.57E-01	4.57E-01	4.57E-01
Cr-51	5.58E+00	3.34E+00	1.23E+00	7.40E+00	1.40E+03	0.00E+00	0.00E+00
Mn-54	1.35E+03	0.00E+00	2.10E+03	0.00E+00	2.16E+04	0.00E+00	7.06E+03
Mn-56	3.15E+01	0.00E+00	2.26E+02	0.00E+00	5.67E+03	0.00E+00	1.78E+02
Fe-55	8.23E+03	0.00E+00	0.00E+00	1.97E+04	2.03E+04	5.11E+04	3.53E+04
Fe-59	7.27E+04	0.00E+00	0.00E+00	5.30E+04	6.32E+05	8.06E+04	1.90E+05
Co-57	2.36E+02	0.00E+00	0.00E+00	0.00E+00	3.59E+03	0.00E+00	1.42E+02
Co-58	1.35E+03	0.00E+00	0.00E+00	0.00E+00	1.22E+04	0.00E+00	6.03E+02
Co-60	3.82E+03	0.00E+00	0.00E+00	0.00E+00	3.25E+04	0.00E+00	1.73E+03
Ni-65	1.20E+01	0.00E+00	0.00E+00	0.00E+00	6.65E+02	2.02E+02	2.62E+01
Cu-64	1.01E+02	0.00E+00	5.40E+02	0.00E+00	1.83E+04	0.00E+00	2.14E+02
Zn-65	2.32E+05	0.00E+00	3.43E+05	0.00E+00	3.23E+05	1.61E+05	5.13E+05
Zn-69	4.56E+01	0.00E+00	4.26E+02	0.00E+00	9.85E+01	3.43E+02	6.56E+02
As-76	4.42E+01	0.00E+00	8.72E+01	0.00E+00	0.00E+00	0.00E+00	4.62E+01
Br-82	4.07E+00	0.00E+00	0.00E+00	0.00E+00	4.67E+00	0.00E+00	0.00E+00
Br-84	9.39E-02	0.00E+00	0.00E+00	0.00E+00	7.37E-07	0.00E+00	0.00E+00
Rb-86	2.91E+02	0.00E+00	0.00E+00	0.00E+00	1.23E+02	0.00E+00	6.24E+02
Rb-88	9.49E-01	0.00E+00	0.00E+00	0.00E+00	2.47E-11	0.00E+00	1.79E+00
Rb-89	8.34E-01	0.00E+00	0.00E+00	0.00E+00	6.89E-14	0.00E+00	1.19E+00
Sr-89	1.43E+02	0.00E+00	0.00E+00	0.00E+00	8.00E+02	4.99E+03	0.00E+00
Sr-90	2.83E+03	0.00E+00	0.00E+00	0.00E+00	3.55E+03	1.41E+05	0.00E+00
Sr-91	3.71E+00	0.00E+00	0.00E+00	0.00E+00	4.37E+02	9.18E+01	0.00E+00
Sr-92	1.51E+00	0.00E+00	0.00E+00	0.00E+00	6.90E+02	3.48E+01	0.00E+00
Y-90	1.63E-01	0.00E+00	0.00E+00	0.00E+00	6.42E+04	6.06E+00	0.00E+00
Y-91m	2.22E-03	0.00E+00	0.00E+00	0.00E+00	1.68E-01	5.73E-02	0.00E+00
Y-92	1.56E-02	0.00E+00	0.00E+00	0.00E+00	9.32E+03	5.32E-01	0.00E+00
Zr-95	3.46E+00	0.00E+00	8.02E+00	0.00E+00	1.62E+04	1.59E+01	5.11E+00
Zr-97	8.13E-02	0.00E+00	2.68E-01	0.00E+00	5.51E+04	8.81E-01	1.78E-01
Nb-95	1.34E+02	0.00E+00	2.46E+02	0.00E+00	1.51E+06	4.47E+02	2.49E+02
Mo-99	2.43E+01	0.00E+00	2.89E+02	0.00E+00	2.96E+02	0.00E+00	1.28E+02
Tc-101	1.88E-01	0.00E+00	3.46E-01	9.81E-03	5.77E-14	1.33E-02	1.92E-02
Ru-103	4.60E+01	0.00E+00	4.07E+02	0.00E+00	1.25E+04	1.07E+02	0.00E+00
Ru-105	3.51E+00	0.00E+00	1.15E+02	0.00E+00	5.44E+03	8.89E+00	0.00E+00
Ru-106	2.01E+02	0.00E+00	3.06E+03	0.00E+00	1.03E+05	1.59E+03	0.00E+00
Ag-110m	8.60E+02	0.00E+00	2.85E+03	0.00E+00	5.91E+05	1.56E+03	1.45E+03
Sn-113	3.53E+03	9.85E+02	0.00E+00	0.00E+00	0.00E+00	6.06E+04	1.66E+03
Sn-117m	8.76E+02	2.52E+02	0.00E+00	0.00E+00	0.00E+00	3.02E+03	3.41E+02
Sb-122	6.65E+00	3.09E-01	0.00E+00	1.18E+01	0.00E+00	2.19E+01	4.47E-01
Sb-124	1.09E+02	6.70E-01	0.00E+00	2.15E+02	7.84E+03	2.76E+02	5.22E+00
Sb-125	4.20E+01	1.79E-01	0.00E+00	1.36E+02	1.94E+03	1.77E+02	1.97E+00

PACIFIC GAS AND ELECTRIC COMPANY
 DIABLO CANYON POWER PLANT

NUMBER CAP A-8
 REVISION 26
 PAGE 50 OF 62
 UNITS 1 AND 2

TITLE: Off-Site Dose Calculations

LRW COMPOSITE DOSE FACTORS¹, A₁₀,
 FOR ADULTS AT A SALTWATER SITE
 (mrem/hour per μ Ci/ml)
 organ "o"

Nuclide	Tot Body	Thyroid	Kidney	Lung	GI-LLI	Bone	Liver
Te-129m	1.47E+02	3.20E+02	3.89E+03	0.00E+00	4.69E+03	9.31E+02	3.47E+02
Te-129	6.19E-01	1.95E+00	1.07E+01	0.00E+00	1.92E+00	2.54E+00	9.55E-01
Te-131m	5.71E+01	1.08E+02	6.94E+02	0.00E+00	6.80E+03	1.40E+02	6.85E+01
Te-131	5.03E-01	1.31E+00	6.99E+00	0.00E+00	2.26E-01	1.59E+00	6.66E-01
Te-132	1.24E+02	1.46E+02	1.27E+03	0.00E+00	6.24E+03	2.04E+02	1.32E+02
I-131	1.79E+02	1.02E+05	5.35E+02	0.00E+00	8.23E+01	2.18E+02	3.12E+02
I-132	9.96E+00	9.96E+02	4.54E+01	0.00E+00	5.35E+00	1.06E+01	2.85E+01
I-133	3.95E+01	1.90E+04	2.26E+02	0.00E+00	1.16E+02	7.45E+01	1.30E+02
I-134	5.40E+00	2.62E+02	2.40E+01	0.00E+00	1.32E-02	5.56E+00	1.51E+01
I-135	2.24E+01	4.01E+03	9.75E+01	0.00E+00	6.87E+01	2.32E+01	6.08E+01
Cs-134	1.33E+04	0.00E+00	5.27E+03	1.75E+03	2.85E+02	6.84E+03	1.63E+04
Cs-136	2.04E+03	0.00E+00	1.57E+03	2.16E+02	3.21E+02	7.16E+02	2.83E+03
Cs-137	7.85E+03	0.00E+00	4.07E+03	1.35E+03	2.32E+02	8.77E+03	1.20E+04
Cs-138	5.94E+00	0.00E+00	8.81E+00	8.70E-01	5.12E-05	6.07E+00	1.20E+01
Ba-139	2.30E-01	0.00E+00	5.23E-03	3.17E-03	1.39E+01	7.85E+00	5.59E-03
Ba-140	1.08E+02	0.00E+00	7.02E-01	1.18E+00	3.38E+03	1.64E+03	2.06E+00
Ba-141	1.29E-01	0.00E+00	2.68E-03	1.63E-03	1.80E-09	3.81E+00	2.88E-03
La-140	2.10E-01	0.00E+00	0.00E+00	0.00E+00	5.83E+04	1.57E+00	7.94E-01
La-142	9.13E-03	0.00E+00	0.00E+00	0.00E+00	2.68E+02	8.06E-02	3.67E-02
Ce-141	2.63E-01	0.00E+00	1.08E+00	0.00E+00	8.86E+03	3.43E+00	2.32E+00
Ce-143	4.94E-02	0.00E+00	1.97E-01	0.00E+00	1.67E+04	6.04E-01	4.46E+02
Ce-144	9.59E+00	0.00E+00	4.43E+01	0.00E+00	6.04E+04	1.79E+02	7.47E+01
Pr-144	9.64E-04	0.00E+00	4.44E-03	0.00E+00	2.73E-09	1.90E-02	7.87E-03
Nd-147	2.74E-01	0.00E+00	2.68E+00	0.00E+00	2.20E+04	3.96E+00	4.58E+00
W-187	2.68E+00	0.00E+00	0.00E+00	0.00E+00	2.51E+03	9.16E+00	7.66E+00
Np-239	1.91E-03	0.00E+00	1.08E-02	0.00E+00	7.11E+02	3.53E-02	3.47E-03

¹ Dose factors are based upon NUREG 0133 methodology.

PACIFIC GAS AND ELECTRIC COMPANY
 DIABLO CANYON POWER PLANT

NUMBER CAP A-8
 REVISION 26
 PAGE 51 OF 62
 UNITS 1 AND 2

TITLE: Off-Site Dose Calculations

**TABLE 10.2
 SUMMARY OF LAND USE CENSUS EVALUATION**

Sector	Receptor Description	Distance (miles)	X/Q	D/Q	Comments
N	none				no receptors within 5 miles
NNE	residence	4.4	5.70E-8	9.40E-11	unknown use
	residence	3.3	8.70E-8	1.60E-10	cabin - limited use
NE	residence	4.9	3.70E-8	6.20E-11	full time occupancy
ENE	residence	4.4	4.10E-8	7.60E-11	full time occupancy
	residence	5.0	3.40E-8	6.00E-11	full time occupancy
E	residence	4.0	5.40E-8	1.40E-10	cabin - unknown use
	residence	3.7	6.10E-8	1.60E-10	part time occupancy
	residence + garden	4.5	4.40E-8	1.10E-10	full time occupancy
ESE	oat hay and sugar peas	3.3	1.50E-7	9.20E-10	field workers present only during the day - critical receptor ground plane, inhalation, and vegetation ingestion dose assessed at this location
SE	none				no receptors within 5 miles
SSE	none				over water
S	none				over water
SSW	none				over water
SW	none				over water
WSW	none				over water
W	none				over water
WNW	none				over water
NW	highest site boundary dispersion value	0.5	5.50E-6	1.90E-8	Gas effluent dose rates. PRRLs and HASPs evaluated at this location.
	residence	1.2	1.20E-6	4.30E-9	cabin - very limited use
	residence	3.6	2.20E-7	6.40E-10	full time occupancy
NNW	residence	1.5	7.40E-7	2.20E-9	full time occupancy (trailer) - critical receptor ground plane and inhalation dose assessed at this location

PACIFIC GAS AND ELECTRIC COMPANY
 DIABLO CANYON POWER PLANT

NUMBER CAP A-8
 REVISION 26
 PAGE 52 OF 62
 UNITS 1 AND 2

TITLE: Off-Site Dose Calculations

TABLE 10.3

GRW DOSE FACTORS FOR NOBLE GASES¹

Radionuclide	Whole Body Dose Factor K _i (mrem/yr per μCi/m ³)	Skin Dose Factor L _i (mrem/yr per μCi/m ³)	Gamma Air Dose Factor M _i (mrad/yr per μCi/m ³)	Beta Air Dose Factor N _i (mrad/yr per μCi/m ³)
Kr-83m	7.56E-02	----	1.93E+01	2.88E+02
Kr-85m	1.17E+03	1.46E+03	1.23E+03	1.97E+03
Kr-85	1.61E+01	1.34E+03	1.72E+01	1.95E+03
Kr-87	5.92E+03	9.73E+03	6.17E+03	1.03E+04
Kr-88	1.47E+04	2.37E+03	1.52E+04	2.93E+03
Kr-89	1.66E+04	1.01E+04	1.73E+04	1.06E+04
Kr-90	1.56E+04	7.29E+03	1.63E+04	7.83E+03
Xe-131m	9.15E+01	4.76E+02	1.56E+02	1.11E+03
Xe-133m	2.51E+02	9.94E+02	3.27E+02	1.48E+03
Xe-133	2.94E+02	3.06E+02	3.53E+02	1.05E+03
Xe-135m	3.12E+03	7.11E+02	3.36E+03	7.39E+02
Xe-135	1.81E+03	1.86E+03	1.92E+03	2.46E+03
Xe-137	1.42E+03	1.22E+04	1.51E+03	1.27E+04
Xe-138	8.83E+03	4.13E+03	9.21E+03	4.75E+03
Ar-41	8.84E+03	2.69E+03	9.30E+03	3.28E+03

¹ From Table B-1 of Regulatory Guide 1.109 (Rev. 1, Oct. 1977)

PACIFIC GAS AND ELECTRIC COMPANY
DIABLO CANYON POWER PLANT

NUMBER CAP A-8
REVISION 26
PAGE 53 OF 62
UNITS 1 AND 2

TITLE: Off-Site Dose Calculations

TABLE 10.4
CHILD INHALATION PATHWAY DOSE FACTORS FOR WORST CASE ORGAN

<u>Radionuclide</u>	<u>P_i^w</u>
H-3	6.40E+02
CR-51	1.70E+04
MN-54	1.58E+06
FE-59	1.27E+06
CO-58	1.11E+06
CO-60	7.07E+06
ZN-65	9.95E+05
RB-86	1.98E+05
SR-89	2.16E+06
Y-90	2.68E+05
SR-90	3.85E+07
ZR-95	2.23E+06
NB-95	6.14E+05
RU-103	6.62E+05
RU-106	1.43E+07
AG-110M	5.48E+06
SB-124	3.24E+06
SB-125	2.32E+06
TE-129M	1.76E+06
I-131	1.62E+07
I-133	3.85E+06
CS-134	1.01E+06
CS-136	1.71E+05
CS-137	9.07E+05
BA-140	1.74E+06
CE-141	5.44E+05
CE-144	1.20E+07
ND-147	3.28E+05

PACIFIC GAS AND ELECTRIC COMPANY
 DIABLO CANYON POWER PLANT

NUMBER CAP A-8
 REVISION 26
 PAGE 54 OF 62
 UNITS 1 AND 2

TITLE: Off-Site Dose Calculations

TABLE 10.5
 GROUND PLANE DOSE FACTORS

GRW DOSE PARAMETERS¹, R_{i GP} FOR RADIOIODINES, RADIOACTIVE
 PARTICULATES, AND ANY RADIONUCLIDE OTHER THAN
 NOBLE GAS (IPT), GASEOUS EFFLUENTS (GRW),
 ANY AGE GROUP, GROUND PLANE PATHWAY
 (mrem/yr per $\mu\text{Ci}/(\text{sec m}^2)$)

Nuclide	Bone	Liver	T Body	Thyroid	Kidney	Lung	GI-LLI
H-3	0.00E+00	0.00E+00	0.00E+00	0.00E+00	0.00E+00	0.00E+00	0.00E+00
CR-51	4.65E+06	4.65E+06	4.65E+06	4.65E+06	4.65E+06	4.65E+06	4.65E+06
MN-54	1.38E+09	1.38E+09	1.38E+09	1.38E+09	1.38E+09	1.38E+09	1.38E+09
FE-59	2.73E+08	2.73E+08	2.73E+08	2.73E+08	2.73E+08	2.73E+08	2.73E+08
CO-58	3.80E+08	3.80E+08	3.80E+08	3.80E+08	3.80E+08	3.80E+08	3.80E+08
CO-60	2.15E+10	2.15E+10	2.15E+10	2.15E+10	2.15E+10	2.15E+10	2.15E+10
ZN-65	7.46E+08	7.46E+08	7.46E+08	7.46E+08	7.46E+08	7.46E+08	7.46E+08
RB-86	8.98E+06	8.98E+06	8.98E+06	8.98E+06	8.98E+06	8.98E+06	8.98E+06
SR-89	2.16E+04	2.16E+04	2.16E+04	2.16E+04	2.16E+04	2.16E+04	2.16E+04
Y-90	4.50E+03	4.50E+03	4.50E+03	4.50E+03	4.50E+03	4.50E+03	4.50E+03
SR-90	0.00E+00	0.00E+00	0.00E+00	0.00E+00	0.00E+00	0.00E+00	0.00E+00
ZR-95	2.45E+08	2.45E+08	2.45E+08	2.45E+08	2.45E+08	2.45E+08	2.45E+08
NB-95	1.37E+08	1.37E+08	1.37E+08	1.37E+08	1.37E+08	1.37E+08	1.37E+08
RU-103	1.08E+08	1.08E+08	1.08E+08	1.08E+08	1.08E+08	1.08E+08	1.08E+08
RU-106	4.20E+08	4.20E+08	4.20E+08	4.20E+08	4.20E+08	4.20E+08	4.20E+08
AG-110M	3.45E+09	3.45E+09	3.45E+09	3.45E+09	3.45E+09	3.45E+09	3.45E+09
SB-124	5.99E+08	5.99E+08	5.99E+08	5.99E+08	5.99E+08	5.99E+08	5.99E+08
SB-125	2.34E+09	2.34E+09	2.34E+09	2.34E+09	2.34E+09	2.34E+09	2.34E+09
TE-129M	1.98E+07	1.98E+07	1.98E+07	1.98E+07	1.98E+07	1.98E+07	1.98E+07
I-131	1.72E+07	1.72E+07	1.72E+07	1.72E+07	1.72E+07	1.72E+07	1.72E+07
I-133	2.45E+06	2.45E+06	2.45E+06	2.45E+06	2.45E+06	2.45E+06	2.45E+06
CS-134	6.90E+09	6.90E+09	6.90E+09	6.90E+09	6.90E+09	6.90E+09	6.90E+09
CS-136	1.51E+08	1.51E+08	1.51E+08	1.51E+08	1.51E+08	1.51E+08	1.51E+08
CS-137	1.03E+10	1.03E+10	1.03E+10	1.03E+10	1.03E+10	1.03E+10	1.03E+10
BA-140	2.05E+07	2.05E+07	2.05E+07	2.05E+07	2.05E+07	2.05E+07	2.05E+07
CE-141	1.37E+07	1.37E+07	1.37E+07	1.37E+07	1.37E+07	1.37E+07	1.37E+07
CE-144	6.96E+07	6.96E+07	6.96E+07	6.96E+07	6.96E+07	6.96E+07	6.96E+07
ND-147	8.39E+06	8.39E+06	8.39E+06	8.39E+06	8.39E+06	8.39E+06	8.39E+06

¹ Dose factors are based upon NUREG 0133 methodology.

PACIFIC GAS AND ELECTRIC COMPANY
DIABLO CANYON POWER PLANT

NUMBER CAP A-8
REVISION 26
PAGE 55 OF 62
UNITS 1 AND 2

TITLE: Off-Site Dose Calculations

TABLE 10.6

GRW DOSE PARAMETERS FOR RADIOIODINES, RADIOACTIVE PARTICULATES, AND ANY RADIONUCLIDE OTHER THAN NOBLE GAS (IPT), GASEOUS EFFLUENTS (GRW)

PACIFIC GAS AND ELECTRIC COMPANY
 DIABLO CANYON POWER PLANT

NUMBER CAP A-8
 REVISION 26
 PAGE 56 OF 62
 UNITS 1 AND 2

TITLE: Off-Site Dose Calculations

TABLE 10.6.1

GRW DOSE PARAMETERS¹ FOR RADIOIODINES, RADIOACTIVE PARTICULATES, AND ANY
 RADIONUCLIDE OTHER THAN NOBLE GAS (IPT), GASEOUS EFFLUENTS (GRW), INFANT
 AGE GROUP, INHALATION PATHWAY ORGAN "O" (mrem/yr per $\mu\text{Ci}/\text{m}^3$) $R_{i,Inhal}$

Nuclide	Bone	Liver	T Body	Thyroid	Kidney	Lung	GI-LLI
H-3	0.00E+00	3.68E+02	3.68E+02	3.68E+02	3.68E+02	3.68E+02	3.68E+02
CR-51	0.00E+00	0.00E+00	8.95E+01	5.75E+01	1.32E+01	1.28E+04	3.57E+02
MN-54	0.00E+00	2.53E+04	4.98E+03	0.00E+00	4.98E+03	1.00E+06	7.06E+03
FE-59	1.36E+04	2.35E+04	9.48E+03	0.00E+00	0.00E+00	1.02E+06	2.48E+04
CO-58	0.00E+00	1.22E+03	1.82E+03	0.00E+00	0.00E+00	7.77E+05	1.11E+04
CO-60	0.00E+00	8.02E+03	1.18E+04	0.00E+00	0.00E+00	4.51E+06	3.19E+04
ZN-65	1.93E+04	6.26E+04	3.11E+04	0.00E+00	3.25E+04	6.47E+05	5.14E+04
RB-86	0.00E+00	1.90E+05	8.82E+04	0.00E+00	0.00E+00	0.00E+00	3.04E+03
SR-89	3.98E+05	0.00E+00	1.14E+04	0.00E+00	0.00E+00	2.03E+06	6.40E+04
Y-90	3.29E+03	0.00E+00	8.82E+01	0.00E+00	0.00E+00	2.69E+05	1.04E+05
SR-90	1.55E+07	0.00E+00	3.12E+05	0.00E+00	0.00E+00	1.12E+07	1.31E+05
ZR-95	1.15E+05	2.79E+04	2.03E+04	0.00E+00	3.11E+04	1.75E+06	2.17E+04
NB-95	1.57E+04	6.43E+03	3.78E+03	0.00E+00	4.72E+03	4.79E+05	1.27E+04
RU-103	2.02E+03	0.00E+00	6.79E+02	0.00E+00	4.24E+03	5.52E+05	1.61E+04
RU-106	8.68E+04	0.00E+00	1.09E+04	0.00E+00	1.07E+05	1.16E+07	1.64E+05
AG-110M	9.98E+03	7.22E+03	5.00E+03	0.00E+00	1.09E+04	3.67E+06	3.30E+04
SB-124	3.79E+04	5.56E+02	1.20E+04	1.01E+02	0.00E+00	2.65E+06	5.91E+04
SB-125	5.17E+04	4.77E+02	1.09E+04	6.23E+01	0.00E+00	1.64E+06	1.47E+04
TE-129M	1.41E+04	6.09E+03	2.23E+03	5.47E+03	3.18E+04	1.68E+06	6.90E+04
I-131	3.79E+04	4.44E+04	1.96E+04	1.48E+07	5.18E+04	0.00E+00	1.06E+03
I-133	1.32E+04	1.92E+04	5.60E+03	3.56E+06	2.24E+04	0.00E+00	2.16E+03
CS-134	3.96E+05	7.03E+05	7.45E+04	0.00E+00	1.90E+05	7.97E+04	1.33E+03
CS-136	4.83E+04	1.35E+05	5.29E+04	0.00E+00	5.64E+04	1.18E+04	1.43E+03
CS-137	5.49E+05	6.12E+05	4.55E+04	0.00E+00	1.72E+05	7.13E+04	1.33E+03
BA-140	5.60E+04	5.60E+01	2.90E+03	0.00E+00	1.34E+01	1.60E+06	3.84E+04
CE-141	2.77E+04	1.67E+04	1.99E+03	0.00E+00	5.25E+03	5.17E+05	2.16E+04
CE-144	3.19E+06	1.21E+06	1.76E+05	0.00E+00	5.38E+05	9.84E+06	1.48E+05
ND-147	7.94E+03	8.13E+03	5.00E+02	0.00E+00	3.15E+03	3.22E+05	3.12E+04

¹ Dose factors are based upon NUREG 0133 methodology.

PACIFIC GAS AND ELECTRIC COMPANY
 DIABLO CANYON POWER PLANT

NUMBER CAP A-8
 REVISION 26
 PAGE 57 OF 62
 UNITS 1 AND 2

TITLE: Off-Site Dose Calculations

TABLE 10.6.2

GRW DOSE PARAMETERS¹ FOR RADIOIODINES, RADIOACTIVE PARTICULATES, AND ANY
 RADIONUCLIDE OTHER THAN NOBLE GAS (IPT), GASEOUS EFFLUENTS (GRW), CHILD
 AGE GROUP, INHALATION PATHWAY ORGAN "O" (mrem/yr per $\mu\text{Ci}/\text{m}^3$) $R_{i,Inhal}$

Nuclide	Bone	Liver	T Body	Thyroid	Kidney	Lung	GI-LLI
H-3	0.00E+00	6.40E+02	6.40E+02	6.40E+02	6.40E+02	6.40E+02	6.40E+02
CR-51	0.00E+00	0.00E+00	1.54E+02	8.55E+01	2.43E+01	1.70E+04	1.08E+03
MN-54	0.00E+00	4.29E+04	9.51E+03	0.00E+00	1.00E+04	1.58E+06	2.29E+04
FE-59	2.07E+04	3.34E+04	1.67E+04	0.00E+00	0.00E+00	1.27E+06	7.07E+04
CO-58	0.00E+00	1.77E+03	3.16E+03	0.00E+00	0.00E+00	1.11E+06	3.44E+04
CO-60	0.00E+00	1.31E+04	2.26E+04	0.00E+00	0.00E+00	7.07E+06	9.62E+04
ZN-65	4.26E+04	1.13E+05	7.03E+04	0.00E+00	7.14E+04	9.95E+05	1.63E+04
RB-86	0.00E+00	1.98E+05	1.14E+05	0.00E+00	0.00E+00	0.00E+00	7.99E+03
SR-89	5.99E+05	0.00E+00	1.72E+04	0.00E+00	0.00E+00	2.16E+06	1.67E+05
Y-90	4.11E+03	0.00E+00	1.11E+02	0.00E+00	0.00E+00	2.62E+05	2.68E+05
SR-90	3.85E+07	0.00E+00	7.66E+05	0.00E+00	0.00E+00	1.48E+07	3.43E+05
ZR-95	1.90E+05	4.18E+04	3.70E+04	0.00E+00	5.96E+04	2.23E+06	6.11E+04
NB-95	2.35E+04	9.18E+03	6.55E+03	0.00E+00	8.62E+03	6.14E+05	3.70E+04
RU-103	2.79E+03	0.00E+00	1.07E+03	0.00E+00	7.03E+03	6.62E+05	4.48E+04
RU-106	1.36E+05	0.00E+00	1.69E+04	0.00E+00	1.84E+05	1.43E+07	4.29E+05
AG-110M	1.69E+04	1.14E+04	9.14E+03	0.00E+00	2.12E+04	5.48E+06	1.00E+05
SB-124	5.74E+04	7.40E+02	2.00E+04	1.26E+02	0.00E+00	3.24E+06	1.64E+05
SB-125	9.84E+04	7.59E+02	2.07E+04	9.10E+01	0.00E+00	2.32E+06	4.03E+04
TE-129M	1.92E+04	6.85E+03	3.04E+03	6.33E+03	5.03E+04	1.76E+06	1.82E+05
I-131	4.81E+04	4.81E+04	2.73E+04	1.62E+07	7.88E+04	0.00E+00	2.84E+03
I-133	1.66E+04	2.03E+04	7.70E+03	3.85E+06	3.38E+04	0.00E+00	5.48E+03
CS-134	6.51E+05	1.01E+06	2.25E+05	0.00E+00	3.30E+05	1.21E+05	3.85E+03
CS-136	6.51E+04	1.71E+05	1.16E+05	0.00E+00	9.55E+04	1.45E+04	4.18E+03
CS-137	9.07E+05	8.25E+05	1.28E+05	0.00E+00	2.82E+05	1.04E+05	3.62E+03
BA-140	7.40E+04	6.48E+01	4.33E+03	0.00E+00	2.11E+01	1.74E+06	1.02E+05
CE-141	3.92E+04	1.95E+04	2.90E+03	0.00E+00	8.55E+03	5.44E+05	5.66E+04
CE-144	6.77E+06	2.12E+06	3.61E+05	0.00E+00	1.17E+06	1.20E+07	3.89E+05
ND-147	1.08E+04	8.73E+03	6.81E+02	0.00E+00	4.81E+03	3.28E+05	8.21E+04

¹ Dose factors are based upon NUREG 0133 methodology.

PACIFIC GAS AND ELECTRIC COMPANY
 DIABLO CANYON POWER PLANT

NUMBER CAP A-8
 REVISION 26
 PAGE 58 OF 62
 UNITS 1 AND 2

TITLE: Off-Site Dose Calculations

TABLE 10.6.3

GRW DOSE PARAMETERS¹ FOR RADIOIODINES, RADIOACTIVE PARTICULATES, AND ANY RADIONUCLIDE OTHER THAN NOBLE GAS (IPT), GASEOUS EFFLUENTS (GRW), TEEN AGE GROUP, INHALATION PATHWAY ORGAN "O" (mrem/yr per $\mu\text{Ci}/\text{m}^3$) $R_{i,Inhal}$

Nuclide	Bone	Liver	T Body	Thyroid	Kidney	Lung	GI-LLI
H-3	0.00E+00	7.25E+02	7.25E+02	7.25E+02	7.25E+02	7.25E+02	7.25E+02
CR-51	0.00E+00	0.00E+00	1.35E+02	7.50E+01	3.07E+01	2.10E+04	3.00E+03
MN-54	0.00E+00	5.11E+04	8.40E+03	0.00E+00	1.27E+04	1.98E+06	6.68E+04
FE-59	1.59E+04	3.70E+04	1.43E+04	0.00E+00	0.00E+00	1.53E+06	1.78E+05
CO-58	0.00E+00	2.07E+03	2.78E+03	0.00E+00	0.00E+00	1.34E+06	9.52E+04
CO-60	0.00E+00	1.51E+04	1.98E+04	0.00E+00	0.00E+00	8.72E+06	2.59E+05
ZN-65	3.86E+04	1.34E+05	6.24E+04	0.00E+00	8.64E+04	1.24E+06	4.66E+04
RB-86	0.00E+00	1.90E+05	8.40E+04	0.00E+00	0.00E+00	0.00E+00	1.77E+04
SR-89	4.34E+05	0.00E+00	1.25E+04	0.00E+00	0.00E+00	2.42E+06	3.71E+05
Y-90	2.98E+03	0.00E+00	8.00E+01	0.00E+00	0.00E+00	2.93E+05	5.59E+05
SR-90	3.31E+07	0.00E+00	6.66E+05	0.00E+00	0.00E+00	1.65E+07	7.65E+05
ZR-95	1.46E+05	4.58E+04	3.15E+04	0.00E+00	6.74E+04	2.69E+06	1.49E+05
NB-95	1.86E+04	1.03E+04	5.66E+03	0.00E+00	1.00E+04	7.51E+05	9.68E+04
RU-103	2.10E+03	0.00E+00	8.96E+02	0.00E+00	7.43E+03	7.83E+05	1.09E+05
RU-106	9.84E+04	0.00E+00	1.24E+04	0.00E+00	1.90E+05	1.61E+07	9.60E+05
AG-110M	1.38E+04	1.31E+04	7.99E+03	0.00E+00	2.50E+04	6.75E+06	2.73E+05
SB-124	4.30E+04	7.94E+02	1.68E+04	9.76E+01	0.00E+00	3.85E+06	3.98E+05
SB-125	7.38E+04	8.08E+02	1.72E+04	7.04E+01	0.00E+00	2.74E+06	9.92E+04
TE-129M	1.39E+04	6.58E+03	2.25E+03	4.58E+03	5.19E+04	1.98E+06	4.05E+05
I-131	3.54E+04	4.91E+04	2.64E+04	1.46E+07	8.40E+04	0.00E+00	6.49E+03
I-133	1.22E+04	2.05E+04	6.22E+03	2.92E+06	3.59E+04	0.00E+00	1.03E+04
CS-134	5.02E+05	1.13E+06	5.49E+05	0.00E+00	3.75E+05	1.46E+05	9.76E+03
CS-136	5.15E+04	1.94E+05	1.37E+05	0.00E+00	1.10E+05	1.78E+04	1.09E+04
CS-137	6.70E+05	8.48E+05	3.11E+05	0.00E+00	3.04E+05	1.21E+05	8.48E+03
BA-140	5.47E+04	6.70E+01	3.52E+03	0.00E+00	2.28E+01	2.03E+06	2.29E+05
CE-141	2.84E+04	1.90E+04	2.17E+03	0.00E+00	8.88E+03	6.14E+05	1.26E+05
CE-144	4.89E+06	2.02E+06	2.62E+05	0.00E+00	1.21E+06	1.34E+07	8.64E+05
ND-147	7.86E+03	8.56E+03	5.13E+02	0.00E+00	5.02E+03	3.72E+05	1.82E+05

¹ Dose factors are based upon NUREG 0133 methodology.

PACIFIC GAS AND ELECTRIC COMPANY
 DIABLO CANYON POWER PLANT

NUMBER CAP A-8
 REVISION 26
 PAGE 59 OF 62
 UNITS 1 AND 2

TITLE: Off-Site Dose Calculations

TABLE 10.6.4

GRW DOSE PARAMETERS¹ FOR RADIOIODINES, RADIOACTIVE PARTICULATES, AND ANY
 RADIONUCLIDE OTHER THAN NOBLE GAS (IPT), GASEOUS EFFLUENTS (GRW), ADULT
 AGE GROUP, INHALATION PATHWAY ORGAN "O" (mrem/yr per $\mu\text{Ci}/\text{m}^3$) $R_{i,Inhal}$

Nuclide	Bone	Liver	T Body	Thyroid	Kidney	Lung	GI-LLI
H-3	0.00E+00	7.18E+02	7.18E+02	7.18E+02	7.18E+02	7.18E+02	7.18E+02
CR-51	0.00E+00	0.00E+00	1.00E+02	5.95E+01	2.28E+01	1.44E+04	3.32E+03
MN-54	0.00E+00	3.96E+04	6.30E+03	0.00E+00	9.84E+03	1.40E+06	7.74E+04
FE-59	1.18E+04	2.78E+04	1.06E+04	0.00E+00	0.00E+00	1.02E+06	1.88E+05
CO-58	0.00E+00	1.58E+03	2.07E+03	0.00E+00	0.00E+00	9.28E+05	1.06E+05
CO-60	0.00E+00	1.15E+04	1.48E+04	0.00E+00	0.00E+00	5.97E+06	2.85E+05
ZN-65	3.24E+04	1.03E+05	4.66E+04	0.00E+00	6.90E+04	8.64E+05	5.34E+04
RB-86	0.00E+00	1.35E+05	5.90E+04	0.00E+00	0.00E+00	0.00E+00	1.66E+04
SR-89	3.04E+05	0.00E+00	8.72E+03	0.00E+00	0.00E+00	1.40E+06	3.50E+05
Y-90	2.09E+03	0.00E+00	5.61E+01	0.00E+00	0.00E+00	1.70E+05	5.06E+05
SR-90	2.87E+07	0.00E+00	5.77E+05	0.00E+00	0.00E+00	9.60E+06	7.22E+05
ZR-95	1.07E+05	3.44E+04	2.33E+04	0.00E+00	5.42E+04	1.77E+06	1.50E+05
NB-95	1.41E+04	7.82E+03	4.21E+03	0.00E+00	7.74E+03	5.05E+05	1.04E+05
RU-103	1.53E+03	0.00E+00	6.58E+02	0.00E+00	5.83E+03	5.05E+05	1.10E+05
RU-106	6.91E+04	0.00E+00	8.72E+03	0.00E+00	1.34E+05	9.36E+06	9.12E+05
AG-110M	1.08E+04	1.00E+04	5.94E+03	0.00E+00	1.97E+04	4.63E+06	3.02E+05
SB-124	3.12E+04	5.89E+02	1.24E+04	7.55E+01	0.00E+00	2.48E+06	4.06E+05
SB-125	5.34E+04	5.95E+02	1.26E+04	5.40E+01	0.00E+00	1.74E+06	1.01E+05
TE-129M	9.76E+03	4.67E+03	1.58E+03	3.44E+03	3.66E+04	1.16E+06	3.83E+05
I-131	2.52E+04	3.58E+04	2.05E+04	1.19E+07	6.13E+04	0.00E+00	6.28E+03
I-133	8.64E+03	1.48E+04	4.52E+03	2.15E+06	2.58E+04	0.00E+00	8.88E+03
CS-134	3.73E+05	8.48E+05	7.28E+05	0.00E+00	2.87E+05	9.76E+04	1.04E+04
CS-136	3.90E+04	1.46E+05	1.10E+05	0.00E+00	8.56E+04	1.20E+04	1.17E+04
CS-137	4.78E+05	6.21E+05	4.28E+05	0.00E+00	2.22E+05	7.52E+04	8.40E+03
BA-140	3.90E+04	4.90E+01	2.57E+03	0.00E+00	1.67E+01	1.27E+06	2.18E+05
CE-141	1.99E+04	1.35E+04	1.53E+03	0.00E+00	6.26E+03	3.62E+05	1.20E+05
CE-144	3.43E+06	1.43E+06	1.84E+05	0.00E+00	8.48E+05	7.78E+06	8.16E+05
ND-147	5.27E+03	6.10E+03	3.65E+02	0.00E+00	3.56E+03	2.21E+05	1.73E+05

¹ Dose factors are based upon NUREG 0133 methodology.

PACIFIC GAS AND ELECTRIC COMPANY
 DIABLO CANYON POWER PLANT

NUMBER CAP A-8
 REVISION 26
 PAGE 60 OF 62
 UNITS 1 AND 2

TITLE: Off-Site Dose Calculations

TABLE 10.6.5

GRW DOSE PARAMETERS¹ FOR RADIOIODINES, RADIOACTIVE PARTICULATES, AND ANY RADIONUCLIDE OTHER THAN NOBLE GAS (IPT), GASEOUS EFFLUENTS (GRW), CHILD AGE GROUP, VEGETATION PATHWAY ORGAN "O" (mrem/yr per $\mu\text{Ci}/(\text{sec m}^2)$) $R_{i, \text{Veg}}$

Nuclide	Bone	Liver	T Body	Thyroid	Kidney	Lung	GI-LLI
H-3 ²	0.00E+00	2.29E+03	2.29E+03	2.29E+03	2.29E+03	2.29E+03	2.29E+03
CR-51	0.00E+00	0.00E+00	1.17E+05	6.49E+04	1.77E+04	1.18E+05	6.20E+06
MN-54	0.00E+00	6.65E+08	1.77E+08	0.00E+00	1.86E+08	0.00E+00	5.58E+08
FE-59	3.97E+08	6.42E+08	3.20E+08	0.00E+00	0.00E+00	1.86E+08	6.69E+08
CO-58	0.00E+00	6.45E+07	1.97E+08	0.00E+00	0.00E+00	0.00E+00	3.76E+08
CO-60	0.00E+00	3.78E+08	1.12E+09	0.00E+00	0.00E+00	0.00E+00	2.10E+09
ZN-65	8.12E+08	2.16E+09	1.35E+09	0.00E+00	1.36E+09	0.00E+00	3.80E+08
RB-86	0.00E+00	4.54E+08	2.79E+08	0.00E+00	0.00E+00	0.00E+00	2.92E+07
SR-89	3.59E+10	0.00E+00	1.03E+09	0.00E+00	0.00E+00	0.00E+00	1.39E+09
Y-90	2.31E+04	0.00E+00	6.18E+02	0.00E+00	0.00E+00	0.00E+00	6.57E+07
SR-90	1.87E+12	0.00E+00	3.77E+10	0.00E+00	0.00E+00	0.00E+00	1.67E+10
ZR-95	3.86E+06	8.50E+05	7.56E+05	0.00E+00	1.22E+06	0.00E+00	8.86E+08
NB-95	4.12E+05	1.61E+05	1.15E+05	0.00E+00	1.51E+05	0.00E+00	2.97E+08
RU-103	1.53E+07	0.00E+00	5.89E+06	0.00E+00	3.86E+07	0.00E+00	3.96E+08
RU-106	7.45E+08	0.00E+00	9.30E+07	0.00E+00	1.01E+09	0.00E+00	1.16E+10
AG-110M	3.21E+07	2.17E+07	1.74E+07	0.00E+00	4.04E+07	0.00E+00	2.58E+09
SB-124	3.52E+08	4.57E+06	1.23E+08	7.78E+05	0.00E+00	1.96E+08	2.20E+09
SB-125	4.99E+08	3.85E+06	1.05E+08	4.62E+05	0.00E+00	2.78E+08	1.19E+09
TE-129M	8.40E+08	2.35E+08	1.30E+08	2.71E+08	2.47E+09	0.00E+00	1.02E+09
I-131	1.43E+08	1.44E+08	8.17E+07	4.75E+10	2.36E+08	0.00E+00	1.28E+07
I-133	3.52E+06	4.36E+06	1.65E+06	8.09E+08	7.26E+06	0.00E+00	1.76E+06
CS-134	1.60E+10	2.63E+10	5.55E+09	0.00E+00	8.16E+09	2.93E+09	1.42E+08
CS-136	8.18E+07	2.25E+08	1.46E+08	0.00E+00	1.20E+08	1.79E+07	7.90E+06
CS-137	2.39E+10	2.29E+10	3.38E+09	0.00E+00	7.46E+09	2.68E+09	1.43E+08
BA-140	2.77E+08	2.43E+05	1.62E+07	0.00E+00	7.90E+04	1.45E+05	1.40E+08
CE-141	6.55E+05	3.27E+05	4.85E+04	0.00E+00	1.43E+05	0.00E+00	4.08E+08
CE-144	1.27E+08	3.98E+07	6.78E+06	0.00E+00	2.21E+07	0.00E+00	1.04E+10
ND-147	7.27E+04	5.89E+04	4.56E+03	0.00E+00	3.23E+04	0.00E+00	9.33E+07

¹ Dose factors are based upon NUREG 0133 methodology.

² For Tritium the units of the dose parameters are mrem/yr per $\mu\text{Ci}/\text{m}^3$ for all pathways, and they must be multiplied by X/Q.

PACIFIC GAS AND ELECTRIC COMPANY
DIABLO CANYON POWER PLANT

NUMBER CAP A-8
REVISION 26
PAGE 61 OF 62
UNITS 1 AND 2

TITLE: Off-Site Dose Calculations

TABLE 10.6.6

GRW DOSE PARAMETERS¹ FOR RADIOIODINES, RADIOACTIVE PARTICULATES, AND ANY RADIONUCLIDE OTHER THAN NOBLE GAS (IPT), GASEOUS EFFLUENTS (GRW), TEEN AGE GROUP, VEGETATION PATHWAY ORGAN "O" (mrem/yr per $\mu\text{Ci}/(\text{sec m}^2)$) $R_{i, \text{Veg}}$

Nuclide	Bone	Liver	T Body	Thyroid	Kidney	Lung	GI-LLI
H-3 ²	0.00E+00	1.47E+03	1.47E+03	1.47E+03	1.47E+03	1.47E+03	1.47E+03
CR-51	0.00E+00	0.00E+00	6.16E+04	3.42E+04	1.35E+04	8.79E+04	1.03E+07
MN-54	0.00E+00	4.54E+08	9.01E+07	0.00E+00	1.36E+08	0.00E+00	9.32E+08
FE-59	1.79E+08	4.18E+08	1.61E+08	0.00E+00	0.00E+00	1.32E+08	9.89E+08
CO-58	0.00E+00	4.37E+07	1.01E+08	0.00E+00	0.00E+00	0.00E+00	6.02E+08
CO-60	0.00E+00	2.49E+08	5.60E+08	0.00E+00	0.00E+00	0.00E+00	3.24E+09
ZN-65	4.24E+08	1.47E+09	6.86E+08	0.00E+00	9.41E+08	0.00E+00	6.23E+08
RB-86	0.00E+00	2.75E+08	1.29E+08	0.00E+00	0.00E+00	0.00E+00	4.06E+07
SR-89	1.51E+10	0.00E+00	4.33E+08	0.00E+00	0.00E+00	0.00E+00	1.80E+09
Y-90	1.24E+04	0.00E+00	3.35E+02	0.00E+00	0.00E+00	0.00E+00	1.02E+08
SR-90	9.22E+11	0.00E+00	1.84E+10	0.00E+00	0.00E+00	0.00E+00	2.11E+10
ZR-95	1.72E+06	5.44E+05	3.74E+05	0.00E+00	7.99E+05	0.00E+00	1.26E+09
NB-95	1.93E+05	1.07E+05	5.90E+04	0.00E+00	1.04E+05	0.00E+00	4.58E+08
RU-103	6.82E+06	0.00E+00	2.91E+06	0.00E+00	2.40E+07	0.00E+00	5.69E+08
RU-106	3.09E+08	0.00E+00	3.90E+07	0.00E+00	5.97E+08	0.00E+00	1.48E+10
AG-110M	1.52E+07	1.44E+07	8.73E+06	0.00E+00	2.74E+07	0.00E+00	4.03E+09
SB-124	1.55E+08	2.85E+06	6.03E+07	3.51E+05	0.00E+00	1.35E+08	3.11E+09
SB-125	2.14E+08	2.34E+06	5.01E+07	2.05E+05	0.00E+00	1.88E+08	1.67E+09
TE-129M	3.61E+08	1.34E+08	5.72E+07	1.17E+08	1.51E+09	0.00E+00	1.36E+09
I-131	7.68E+07	1.08E+08	5.78E+07	3.14E+10	1.85E+08	0.00E+00	2.13E+07
I-133	1.93E+06	3.28E+06	1.00E+06	4.58E+08	5.75E+06	0.00E+00	2.48E+06
CS-134	7.10E+09	1.67E+10	7.75E+09	0.00E+00	5.31E+09	2.03E+09	2.08E+08
CS-136	4.35E+07	1.71E+08	1.15E+08	0.00E+00	9.31E+07	1.47E+07	1.38E+07
CS-137	1.01E+10	1.35E+10	4.69E+09	0.00E+00	4.59E+09	1.78E+09	1.92E+08
BA-140	1.38E+08	1.69E+05	8.90E+06	0.00E+00	5.74E+04	1.14E+05	2.13E+08
CE-141	2.83E+05	1.89E+05	2.17E+04	0.00E+00	8.89E+04	0.00E+00	5.40E+08
CE-144	5.27E+07	2.18E+07	2.83E+06	0.00E+00	1.30E+07	0.00E+00	1.33E+10
ND-147	3.67E+04	4.00E+04	2.39E+03	0.00E+00	2.35E+04	0.00E+00	1.44E+08

¹ Dose factors are based upon NUREG 0133 methodology.

² For Tritium the units of the dose parameters are mrem/yr per $\mu\text{Ci}/\text{m}^3$ for all pathways, and they must be multiplied by X/Q.

PACIFIC GAS AND ELECTRIC COMPANY
 DIABLO CANYON POWER PLANT

NUMBER CAP A-8
 REVISION 26
 PAGE 62 OF 62
 UNITS 1 AND 2

TITLE: Off-Site Dose Calculations

TABLE 10.6.7

GRW DOSE PARAMETERS¹ FOR RADIOIODINES, RADIOACTIVE PARTICULATES, AND ANY RADIONUCLIDE OTHER THAN NOBLE GAS (IPT), GASEOUS EFFLUENTS (GRW), ADULT AGE GROUP, VEGETATION PATHWAY ORGAN "O"(mrem/yr per $\mu\text{Ci}/(\text{sec m}^2)$) $R_{t, \text{vegt}}$

Nuclide	Bone	Liver	T Body	Thyroid	Kidney	Lung	GI-LLI
H-3 ²	0.00E+00	1.29E+03	1.29E+03	1.29E+03	1.29E+03	1.29E+03	1.29E+03
CR-51	0.00E+00	0.00E+00	4.64E+04	2.77E+04	1.02E+04	6.15E+04	1.17E+07
MN-54	0.00E+00	3.13E+08	5.97E+07	0.00E+00	9.31E+07	0.00E+00	9.58E+08
FE-59	1.26E+08	2.96E+08	1.13E+08	0.00E+00	0.00E+00	8.27E+07	9.87E+08
CO-58	0.00E+00	3.08E+07	6.90E+07	0.00E+00	0.00E+00	0.00E+00	6.24E+08
CO-60	0.00E+00	1.67E+08	3.69E+08	0.00E+00	0.00E+00	0.00E+00	3.14E+09
ZN-65	3.17E+08	1.01E+09	4.56E+08	0.00E+00	6.75E+08	0.00E+00	6.36E+08
RB-86	0.00E+00	2.20E+08	1.03E+08	0.00E+00	0.00E+00	0.00E+00	4.34E+07
SR-89	9.95E+09	0.00E+00	2.86E+08	0.00E+00	0.00E+00	0.00E+00	1.60E+09
Y-90	1.33E+04	0.00E+00	3.57E+02	0.00E+00	0.00E+00	0.00E+00	1.41E+08
SR-90	6.95E+11	0.00E+00	1.40E+10	0.00E+00	0.00E+00	0.00E+00	1.75E+10
ZR-95	1.18E+06	3.77E+05	2.55E+05	0.00E+00	5.92E+05	0.00E+00	1.20E+09
NB-95	1.43E+05	7.95E+04	4.27E+04	0.00E+00	7.86E+04	0.00E+00	4.83E+08
RU-103	4.77E+06	0.00E+00	2.05E+06	0.00E+00	1.82E+07	0.00E+00	5.57E+08
RU-106	1.93E+08	0.00E+00	2.44E+07	0.00E+00	3.72E+08	0.00E+00	1.25E+10
AG-110M	1.05E+07	9.75E+06	5.79E+06	0.00E+00	1.92E+07	0.00E+00	3.98E+09
SB-124	1.04E+08	1.96E+06	4.11E+07	2.52E+05	0.00E+00	8.08E+07	2.95E+09
SB-125	1.37E+08	1.53E+06	3.25E+07	1.39E+05	0.00E+00	1.05E+08	1.50E+09
TE-129M	2.51E+08	9.37E+07	3.97E+07	8.62E+07	1.05E+09	0.00E+00	1.26E+09
I-131	8.07E+07	1.15E+08	6.62E+07	3.78E+10	1.98E+08	0.00E+00	3.05E+07
I-133	2.08E+06	3.62E+06	1.10E+06	5.32E+08	6.31E+06	0.00E+00	3.25E+06
CS-134	4.67E+09	1.11E+10	9.08E+09	0.00E+00	3.59E+09	1.19E+09	1.94E+08
CS-136	4.25E+07	1.68E+08	1.21E+08	0.00E+00	9.33E+07	1.28E+07	1.90E+07
CS-137	6.36E+09	8.70E+09	5.70E+09	0.00E+00	2.95E+09	9.81E+08	1.68E+08
BA-140	1.29E+08	1.61E+05	8.42E+06	0.00E+00	5.49E+04	9.24E+04	2.65E+08
CE-141	1.97E+05	1.33E+05	1.51E+04	0.00E+00	6.19E+04	0.00E+00	5.09E+08
CE-144	3.29E+07	1.38E+07	1.77E+06	0.00E+00	8.16E+06	0.00E+00	1.11E+10
ND-147	3.37E+04	3.90E+04	2.33E+03	0.00E+00	2.28E+04	0.00E+00	1.87E+08

¹ Dose factors are based upon NUREG 0133 methodology.

² For Tritium the units of the dose parameters are mrem/yr per $\mu\text{Ci}/\text{m}^3$ for all pathways, and they must be multiplied by X/Q.

DIABLO CANYON POWER PLANT
CAP A-8
ATTACHMENT 11.1

1 AND 2

TITLE: Liquid Discharges (LRW) Monitored for Radioactivity

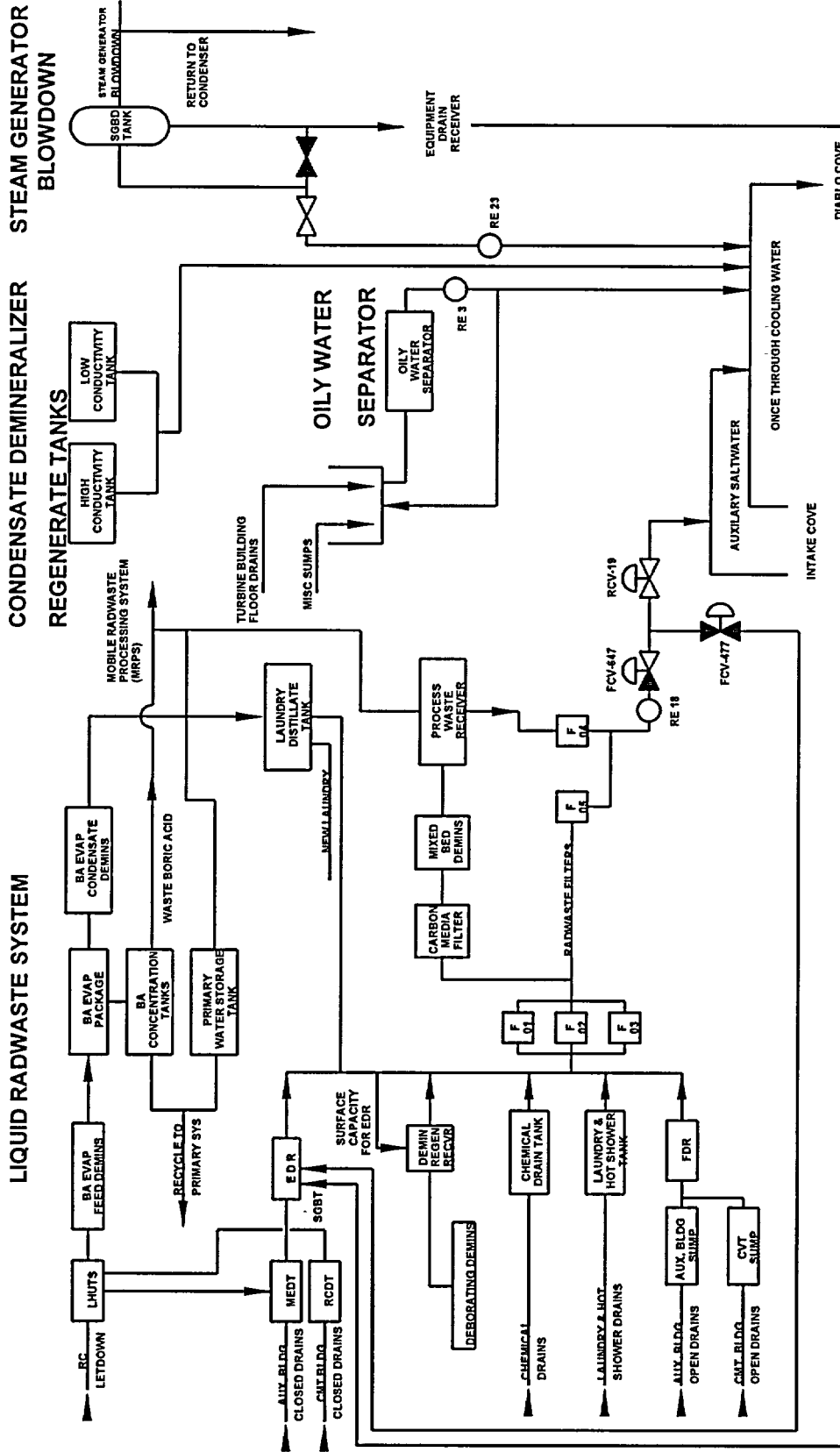

00692326

Attachment 4

Process Control Program

(Procedure RP2.DC2, Revisions 11; includes revision 8 - 11)

PACIFIC GAS AND ELECTRIC COMPANY
NUCLEAR POWER GENERATION
DIABLO CANYON POWER PLANT
ADMINISTRATIVE PROCEDURE

NUMBER RP2.DC2
REVISION 11
PAGE 1 OF 6

TITLE: Process Control Program

10/23/02

EFFECTIVE DATE

PROCEDURE CLASSIFICATION: QUALITY RELATED
SPONSORING ORGANIZATION: RADIATION PROTECTION
REVIEW LEVEL: "A"

1. SCOPE

1.1 The purpose of the Process Control Program (PCP) is to define the necessary program guidance used at the plant to ensure that SOLID RADIOACTIVE WASTE MANAGEMENT activities, in solidifying wet radioactive waste for disposal, conform to the Code of Federal and State Regulations and the Waste Burial Site License Criteria.

2. DISCUSSION

2.1 Solidification is the conversion of wet radioactive wastes into a form that meets shipping and burial ground requirements.

2.2 This procedure implements the requirements of 10 CFR 50.36a and General Design Criterion 60 of Appendix A to 10 CFR Part 50. The process parameters included in establishing the PROCESS CONTROL PROGRAM may include, but are not limited to, waste type, waste pH, waste/liquid/SOLIDIFICATION agent/catalyst ratios, waste oil content, waste principal chemical constituents, and mixing and curing times.

2.3 This procedure contains the individual procedures necessary to perform PCP sample solidifications.

2.4 Cement solidification will not be utilized to stabilize resin or floor drain sludges. Only NRC approved binders, state approved binders or binders submitted for state approval (e.g., Advanced Polymer) may be used to solidify resin or floor drain sludges to meet waste form stability.

3. RESPONSIBILITIES

3.1 Station director has the overall responsibility for the solid radioactive waste activities and reviews and approves changes to the PCP.

3.2 Radiation protection manager is responsible for the implementation of the requirements of this procedure.

3.3 Radwaste engineer is responsible for the development and review of procedures relating to the requirements of this procedure.

3.4 The radwaste foreman is responsible for the implementation of procedures relating to the requirements of this procedure.

3.5 Quality is responsible for verification of compliance with the program requirements.

TITLE: Process Control Program

4. PREREQUISITES

- 4.1 Changes to this procedure requires submission to the US NRC in the annual Radioactive Effluent Release report for the period in which the changes were made.
- 4.2 Any major change to the solid radwaste treatment system shall be reported to the US NRC in the annual Radioactive Effluent Release report for the period in which the change was approved. The discussion of each change shall contain the items listed in Attachment 7.2. This information may be submitted as part of the annual FSAR update in lieu of the annual Radioactive Effluent Release report.

5. INSTRUCTIONS

5.1 GENERAL

It is the policy of the company to conscientiously apply emphasis and attention to those activities associated with generation, processing, packaging, storage and disposal of radioactive waste generated at the plant and to maintain a high level of assurance that radioactive waste products meet or exceed the applicable federal and state regulations and the radioactive waste burial site license criteria.

5.2 WET WASTE

5.2.1 LIQUID/WET WASTE

Liquid/wet wastes are processed to a condition meeting shipping and disposal criteria. These criteria include requirements for immobilization, stability and limits on free standing water (FSW). Specific instructions on processing and required FSW limits are contained in plant procedures and/or qualified vendor procedures.

5.2.2 CONTAINERS, SHIPPING CASKS AND PACKAGING

Solid radioactive waste is processed, packaged and shipped in accordance with plant procedures and/or qualified vendor procedures. These procedures provide specific instructions which ensure the container, shipping casks, and packaging methods comply with the applicable code of federal regulations, state regulations and the radioactive waste burial site license criteria.

5.2.3 SHIPPING AND DISPOSAL

Solid radioactive waste is prepared, loaded and shipped to a federal and/or state licensed radioactive waste disposal facility (burial ground) in accordance with plant procedures and/or qualified vendor procedures. These procedures provide specific instructions which ensure the shipments meet the intended burial site license requirements as well as applicable federal and state regulations.

TITLE: Process Control Program

5.2.4 LABORATORY MIXING OF SAMPLES

Qualified vendor procedures, reviewed and approved by the station director, provide written instructions on sampling, processing and handling waste for the determination of process parameters prior to the actual full scale solidification. These procedures contain the description of the laboratory mixing methods used for these samples.

5.2.5 SOLIDIFICATION PROCESS

Qualified vendors used for radioactive waste solidification are required to provide the Process Control program and written procedures. These procedures and changes thereto must be reviewed and approved by the station director prior to use. Further, the vendors are required to have an NRC topical report, state approval or submittal for state approval on the waste forms which will be solidified. These documents should include:

- a. Description of the solidification process.
- b. Type of solidification used.
- c. Process control parameters.
- d. Parameter boundary conditions.
- e. Proper waste form properties.
- f. Specific instructions to ensure the systems are operated within established process parameters.

5.2.6 SAMPLING PROGRAM FOR SOLIDIFICATION

Vendors, utilized for radioactive waste solidification, are required to include in their approved procedures, requirements to sample at least every tenth batch of the same waste type to ensure solidification and to provide actions to be taken if a sample fails to verify solidification. After a test specimen failure, initial test specimens from three consecutive batches of that waste type must demonstrate solidification before testing requirements of every tenth batch can be resumed. Verification of such sampling is to be accomplished by completing Form 69-10350, "Processing Control Program (PCP) Verification." (See Attachment 7.1.) These forms will be maintained by radiation protection and in the Records Management System (RMS). These procedures and changes thereto must be reviewed and approved by the station director prior to use.

TITLE: Process Control Program

5.2.7 WASTE FORM VERIFICATION

Vendors utilized to process wet wastes are required to include in their procedures provisions to verify that the solidification and/or FSW criteria in the federal and state regulations and the burial site license are met for the specific type of waste being processed.

5.2.8 CORRECTIVE ACTIONS FOR FREE STANDING WATER

Vendors utilized to process wet wastes are required to include in their approved procedures provisions for correcting processed waste in which free standing water in excess of the FSW criteria is detected.

5.2.9 EXOTHERMIC PROCESSES

Vendors utilized for radioactive waste solidification that use an exothermic solidification method are required to include in their approved procedures:

- a. Waste/binder temperature monitoring to mitigate the consequence of adverse exothermic reactions which may occur in the full scale solidification but might not be noticeable in the specimen tests.
- b. Specific process control parameters that shall be met before capping the container.

5.3 OILY WASTE

Oily wastes are shipped to off-site processor for treatment. These processors provide the proper methods to treat oily wastes to comply with federal and state regulations and applicable burial site license criteria.

5.4 SPECIAL CASES

Based upon previous industry experience, the plant foresees the potential for situations arising that may be beyond existing plant capabilities. Anticipating this possibility, provisions are made herein to accommodate such situations in a timely manner by using special techniques or processes. These special cases would be controlled as follows:

- 5.4.1 Implementing procedures would be developed comparable to those used for normal plant solid waste activities based on the guidance of this PCP and incorporating the applicable provisions for process control and testing.
- 5.4.2 The implementing procedure would receive station director approval prior to use.
- 5.4.3 Use of this provision and supporting information would be included in the next annual Radioactive Effluent Release report to the NRC.

TITLE: Process Control Program

5.5 REMEDIAL ACTIONS

- 5.5.1 For waste forms which do not meet federal, state and burial site regulations and requirements, suspension of shipment of the inadequately processed waste and correction of the PCP, procedures or processing equipment shall be performed as necessary to prevent recurrence.
- 5.5.2 For waste forms not prepared in accordance with the PCP, testing of the waste to verify shipping and burial site requirements shall be performed and appropriate administrative action taken to prevent recurrence.

5.6 VENDOR PROCEDURES AND REPORTS

- 5.6.1 The following are maintained in Document Control Master File, Catalog No. TK 9400/ATG-1.
 - a. Allied Technology Group, Inc., Procedure PG01-PCP-05-001, Process Control Program for ATG Radwaste Solidification at Diablo Canyon, Rev. 1
 - b. Topical Report TR-002, 10 CFR 61 Qualified Radioactive Waste Forms, Rev. 1
 - c. Allied Technology Group, Inc., Procedure STD-P-01-035, "Temperature Indicating Device Comparison Test," Rev. 0
 - d. Allied Technology Group, Inc., Procedure STD-P-01-020, "Calibration for a Triple Beam Balance," Rev. 0
 - e. Allied Technology Group, Inc., Procedure STD-P-01-024, "Penetrometer Check Procedure," Rev. 0
- 5.6.2 The following are maintained in Document Control Master File, Catalog No. TK 94001 DTI-1.
 - a. Diversified Technologies, Procedure DTS-AP-PCP-20-OPS-01, PCP for Advanced Polymer Solidification, Rev. E.
 - b. Diversified Technologies, Procedure DT-DCPP-10, PCP for VERI Solidification, Rev 14
 - c. Topical Report DTI-VERI-100-NP-A. VERI™ (Vinyl Ester Resin In Situ) Solidification Process for Low-Level Radioactive Waste, Rev 1
 - d. Topical Report DT-VERI-100-NP-A, Addendum 1.ENCAP Encapsulation Utilizing the VERI Solidification Process.
 - e. Diversified Technologies, Procedure QIP 20-17, pH Meter Calibration, Rev. 3
 - f. Diversified Technologies, Procedure QIP 20-18, Conductivity Meter Calibration, Rev. 2

TITLE: Process Control Program

- g. Diversified Technologies, Procedure QIP-20-16, Thermocouple Calibration, Rev 1
- h. Diversified Technologies, Procedure DT-DCPP-VES-14, PCP for VES Solidification, Rev B.
- i. Topical Report DNS-RSS-200-NP, The Dow Waste Solidification Process for Low-Level Radioactive Waste (Docket Number WM-82).

6. RECORDS

- 6.1 Records of PCP specimen results and Form 69-10350 shall be submitted to the Records Management System on a shipment basis by container per RCP RW-4.

7. ATTACHMENTS

- 7.1 Form 69-10350, "Process Control Program (PCP) Verification," 06/03/93
- 7.2 "Major Change to the Solid Radwaste Treatment System Evaluation," 05/24/01

8. REFERENCES

- 8.1 Title 10 Code of Federal Regulations.
- 8.2 NUREG 0472 and 0473.
- 8.3 NUREG-0800, 11.4 US NRC Standard Review Plan Solid Waste Management Systems.
- 8.4 RCP.DC3, "Dewatering Control Program."
- 8.5 RP2.DC4, "Mobile Service Operating Procedure for Low-Level Radioactive Waste Processing."
- 8.6 NRC Information Notice 88-08, Chemical Reactions with Radioactive Waste Solidification Agents.
- 8.7 ATG Nuclear Services, Quality Assurance Manual, Rev 1.
Document Control Master File, Catalog No. TK-9400/ATG-3.
- 8.8 Technical Position on Waste Form, Revision 1, US NRC, January 1991.
- 8.9 Cement Encapsulation of Cartridge Filters to Provide Waste Form Stability Basis Document, Rev. 1, PG&E NRS Log 0087.
- 8.10 Encapsulation of Cartridge Filters In Vinyl Ester Styrene (VES) to Provide Waste Form Stability Basis Document, Rev. 0, PG&E NRS Log 0072.

DIABLO CANYON POWER PLANT
RP2.DC2
ATTACHMENT 7.2

TITLE: Major Change to the Solid Radwaste Treatment System Evaluation

1. A summary of the evaluation that led to the determination that the change could be made in accordance with 10 CFR 50.59;
2. Sufficient detailed information to totally support the reason for the change without benefit of additional or supplemental information;
3. A detailed description of the equipment, components and processes involved and the interfaces with other plant systems;
4. An evaluation of the change which shows the predicted releases of radioactive materials in liquid and gaseous effluents and/or quantity of solid waste that differ from those previously predicted in the License application and amendments thereto;
5. An evaluation of the change which shows the expected maximum exposures to a MEMBER OF THE PUBLIC in the UNRESTRICTED AREA and to the general population that differ from those previously estimated in the License application and amendments thereto;
6. A comparison of the predicted releases of radioactive materials, in liquid and gaseous effluent and in solid waste, to the actual releases for the period prior to when the changes are to be made;
7. An estimate of the exposure to plant operating personnel as a result of the change; and
8. Documentation of the fact that the change was reviewed and found acceptable.

Attachment 5

**Dewatering Control Program
(Procedure RP2.DC3, Revision 5)**

PACIFIC GAS AND ELECTRIC COMPANY
NUCLEAR POWER GENERATION
DIABLO CANYON POWER PLANT
ADMINISTRATIVE PROCEDURE

NUMBER RP2.DC3
REVISION 5
PAGE 1 OF 4

TITLE: Dewatering Control Program

02/12/02
EFFECTIVE DATE

PROCEDURE CLASSIFICATION: QUALITY RELATED
SPONSORING ORGANIZATION: RADIATION PROTECTION
REVIEW LEVEL: "A"

1. SCOPE

- 1.1 The purpose of the Radwaste Dewatering Control Program is to assure that all dewatering of vendor containers meets State and Federal Regulations as well as Burial Site Criteria for Free Standing Water (FSW).
- 1.2 This Dewatering Process Control Program applies to all vendor dewatering liners and High Integrity Containers (HICs) containing ion exchange and filter media.

2. DISCUSSION

- 2.1 The dewatering system consists of a pump with necessary hoses for connection to the liner or HIC and to the plant interface piping. Liners or HICs supplied by a vendor are preassembled with a hub and/or lateral assembly for dewatering and media retention. Procedures for dewatering are dependent on the waste material to be dewatered and/or the container type.
- 2.2 These procedures, specific to the container and waste material provide instruction for the pumping and settling time sequences as well as; pump rate, total times pumped, and acceptance criteria. Additional contingencies are provided for vessels or liners requiring further steps to meet acceptance criteria and the means of verification of compliance. Methods for recording dewatering data are included in the specific procedure.

3. RESPONSIBILITIES

- 3.1 The radiation protection manager is responsible for implementation of the requirements of this program.
- 3.2 The radwaste engineer is responsible for the development and review of procedures relating to the requirements of this program.
- 3.3 The radwaste foreman is responsible for implementation of the procedures relating to the requirements of this program.
- 3.4 Quality organization is responsible for verification of compliance with the Quality requirements of the dewatering procedures.

TITLE: Dewatering Control Program

4. PREREQUISITES

- 4.1 In order to stabilize a dewatered wet waste an NRC approved HIC can be utilized.
- 4.2 Polyethylene HICs which are listed in the U.S. Ecology Ward Valley license may be used to provide waste stability provided they are disposed of in a concrete overpack as a compensatory measure for their structural deficiency.

5. PRECAUTIONS

- 5.1 Any container of dewatered ion exchange media placed in interim storage shall undergo a dewatering verification prior to shipment for disposal.
- 5.2 No NRC Topical or vendor dewatering test report for spent cartridge filters currently exists. Spent cartridge filters may be loaded into HICs and dewatered for storage. These containers shall not be shipped for disposal prior to encapsulation of the contents or dewatering by an as yet to be determined verifiable process to meet Free Standing Water criteria.

6. INSTRUCTIONS

- 6.1 The Dewatering Control Program for Liners and HICs, shall consist of procedures reviewed and approved by the Station Director.
- 6.2 These procedures shall contain the specific instructions for:
 - 6.2.1 Pumping Time Cycles
 - 6.2.2 Pump Rate
 - 6.2.3 Total Time to be Pumped
 - 6.2.4 Temperature monitoring
 - 6.2.5 Acceptance Criteria of FSW
 - 6.2.6 Pressure Monitoring when Gas Generation is Suspected
 - 6.2.7 Documentation and Records of Dewatering Activities
- 6.3 These procedures shall also specify the type of container and waste media that may be dewatered. Contingencies are provided for additional steps that may be necessary to meet FSW criteria.
- 6.4 GENERAL CONTROL PARAMETERS
 - 6.4.1 Carbon Steel liners for direct disposal at Barnwell are not to be loaded with material over 1 $\mu\text{Ci/cc}$ of nuclides with half lives greater than five years. Liners for direct disposal at Envirocare are not to be loaded with material greater than Class A.
 - 6.4.2 Waste temperature is monitored to mitigate exothermic chemical reactions which are possible when dewatering organic ion exchange materials.
 - 6.4.3 At the end of the appropriate pump cycle, as outlined by the procedure, a measurement of displaced liquid is made.

TITLE: Dewatering Control Program

6.4.4 Records as outlined by the dewatering procedure shall be maintained for all dewatered containers prior to shipment. Copies are delivered to the Radwaste Foreman for indexing with radwaste container paper work.

6.5 Reports

The following are maintained in Document Control Master File, Catalog No. TK 9400/SEG-1.

- 6.5.1 Test Report: LN Technologies, Corp. LN 87-008, DB Series Dewatering Containers, Rev. A.
- 6.5.2 Test Report: LN Technologies, Corp. EN-009, Powdered Resin Dewatering with a Sandpiper Pump, Rev. A.
- 6.5.3 Test Report: Scientific Ecology Group, Inc. EN-005, Summary Test Report for Dewatering Tests on Durasil 70, DT-80 and other media Dewatering Testing, Rev. C.
- 6.5.4 Topical Report for the SEG Composite High Integrity Container LN-87-005, Rev. 1, March 1990, Docket Number WM-93.
- 6.5.5 NRC Technical Evaluation Report LN Composite High-Integrity Container Manufactured by LN Technologies Corporation, Docket Number WM-93.
- 6.5.6 Waste characterization: MMT of Tennessee, PGE-1, 1XE800G.
- 6.5.7 State of South Carolina Department of Health and Environmental Control, Certificate of Compliance - High Integrity Container.
 - a. Certification Number DHEC-HIC-ML-016
 - b. Certification Number DHEC-PL-014
 - c. Certification Number DHEC-PL-010
 - d. Certification Number DHEC-PL-007

7. RECORDS

7.1 Records of dewatering activities shall be submitted to the Records Management System by container.

8. ATTACHMENTS

None

9. REFERENCES

- 9.1 RP2.DC4, "Mobile Service Operating Procedure for Low-Level Radioactive Waste Processing."
- 9.2 NRC Information Notice No. 83-14: Dewatered Spent Ion Exchange Resin Susceptibility to Exothermic Chemical Reaction.

**PACIFIC GAS AND ELECTRIC COMPANY
DIABLO CANYON POWER PLANT**

**NUMBER RP2.DC3
REVISION 5
PAGE 4 OF 4**

TITLE: Dewatering Control Program

- 9.3 NRC Information Notice No. 89-27: Limitations on the Use of Waste Forms and High Integrity Containers for the Disposal of Low-Level Radioactive Waste.
- 9.4 NRC Information Notice No. 90-50: Minimization of Methane Gas in Plant Systems and Radwaste Shipping Containers.
- 9.5 Polyethylene HIC and Concrete Overpack Disposal Basis Document, Rev 1, PG&E NRS Log 0041.
- 9.6 Radioactive Material License issued by the State of California to U.S. Ecology for Ward Valley, 4505-36, Sept. 16, 1993.
- 9.7 ATG Nuclear Services, Quality Assurance Manual, Rev 1, Document Control Master File, Catalog No. TK-9400/ATG-3.

10. SPONSOR

C. Clint Miller

Attachment 6

2002 Land Use Census

2002 LAND USE CENSUS

Diablo Canyon Power Plant (DCPP) radiation protection personnel conducted a land use census in the vicinity of DCPP for 2002. The land use census is based on Nuclear Regulatory Commission (NRC), Regulatory Guide 4.8, "Environmental Technical Specifications for Nuclear Power Plants", and required by DCPP Program Directive CY2, "Radiological Monitoring and Controls Program." The census is conducted at least once per year during the growing season for the Diablo Canyon environs.

The land use census identifies the nearest milk animal and broadleaf producing garden greater than 50 square meters (500 square feet) in each of the landward meteorological sectors within a distance of 8 kilometers (5 miles) of the plant. DCPP IDAP RP1.ID11, "Environmental Radiological Monitoring Program", requires that the nearest residence be identified in each of the landward sectors within a distance of 5 miles.

The land use census was performed by directly contacting individual landowners / tenants and by aerial surveys. The landowners or tenants were contacted between September 26th and October 9th, 2002. The aerial survey was performed on September 30th, 2002.

The census identified one household garden greater than 50 square meters (500 square feet) that produces broadleaf vegetation in the East sector at 4.5 miles from DCPP Unit 1. No milk animals were identified within the first 5 miles of any sector. Much of the area surrounding the plant site is used for rotational cattle grazing by two separate cattle companies. Various numbers of cattle are sold to market at the end of each year. One cattle operation utilizes the land north of the plant site. A second cattle operation utilizes the land south of the plant site. The rancher for the northern cattle operation slaughters about 2 cattle per year for personal consumption. Goats were used for weed abatement for approximately 6 months within the area surrounding the plant site. The rancher from the northern operation owns these goats and also slaughters about 2 goats per year for personal consumption. During 2002, approximately 100 goats are to be sold in mass-market auction. A farm is located on the coastal plateau, along the site access road, in the east-southeast (ESE) sector. The farm starts at approximately 3.3 miles and extends to 4.5 miles from the plant. This commercial farm produces 75% legumes (sugar peas) and 25% cereal grass (oat hay).

A total of 13 residences were identified within the 5-mile radius of the plant that were confirmed or appear to be occupied during 2002. Two abandoned structures are located at 1.6 miles north-northwest (NNW) of the plant. The nearest residence, relative to all sectors, is a small trailer 1.2 miles northwest (NW) of the plant (occupied approximately 1 month per year). Ranchers use this trailer during cattle round-ups. Table 1 summarizes the results of the land use census and Figure 1 shows the locations of the farm, garden, and residences in the vicinity of DCPP.

Table 1

Land Use Census 2002

Distance in Miles from the Unit 1 Center Line to the
 Nearest Milk Animal, Residence, Vegetable Garden

22½ Degree ^(a) Radial Sector	Nearest Milk Animal	Nearest Residence km (mi)	Residence Azimuth Degree	Nearest Vegetable Garden km (mi)
NW	None	1.93 (1.2)	319.5	None
NNW	None	2.41 (1.5)	331	None
N	None	None	—	None
NNE	None	5.3 (3.3)	018.5	None
NE	None	7.89 (4.9)	036	None
ENE	None	7.08 (4.4)	063.5	None
E	None	5.95 (3.7)	097.5	None
E	None	7.24 (4.5)	098	7.24 (4.5)
ESE	None	None	—	5.28 (3.3) ^(b)
SE	None	None	—	None

Table Notation:

- (a) Sectors not shown contain no land beyond the site boundary, other than islets not used for the purposes indicated in this table.
- (b) The vegetable garden indicated is the commercial farm along the westward side of the site access road; however, it does not produce broadleaf vegetation. Area is about 100 acres of land with 6 to 10 rotational plantings per year (not all 100 acres planted at any one time). Commercial crops are about 75% sugar peas and 25% oat hay. The farm starts at approximately 3.3 miles and extends to 4.5 miles from the plant.

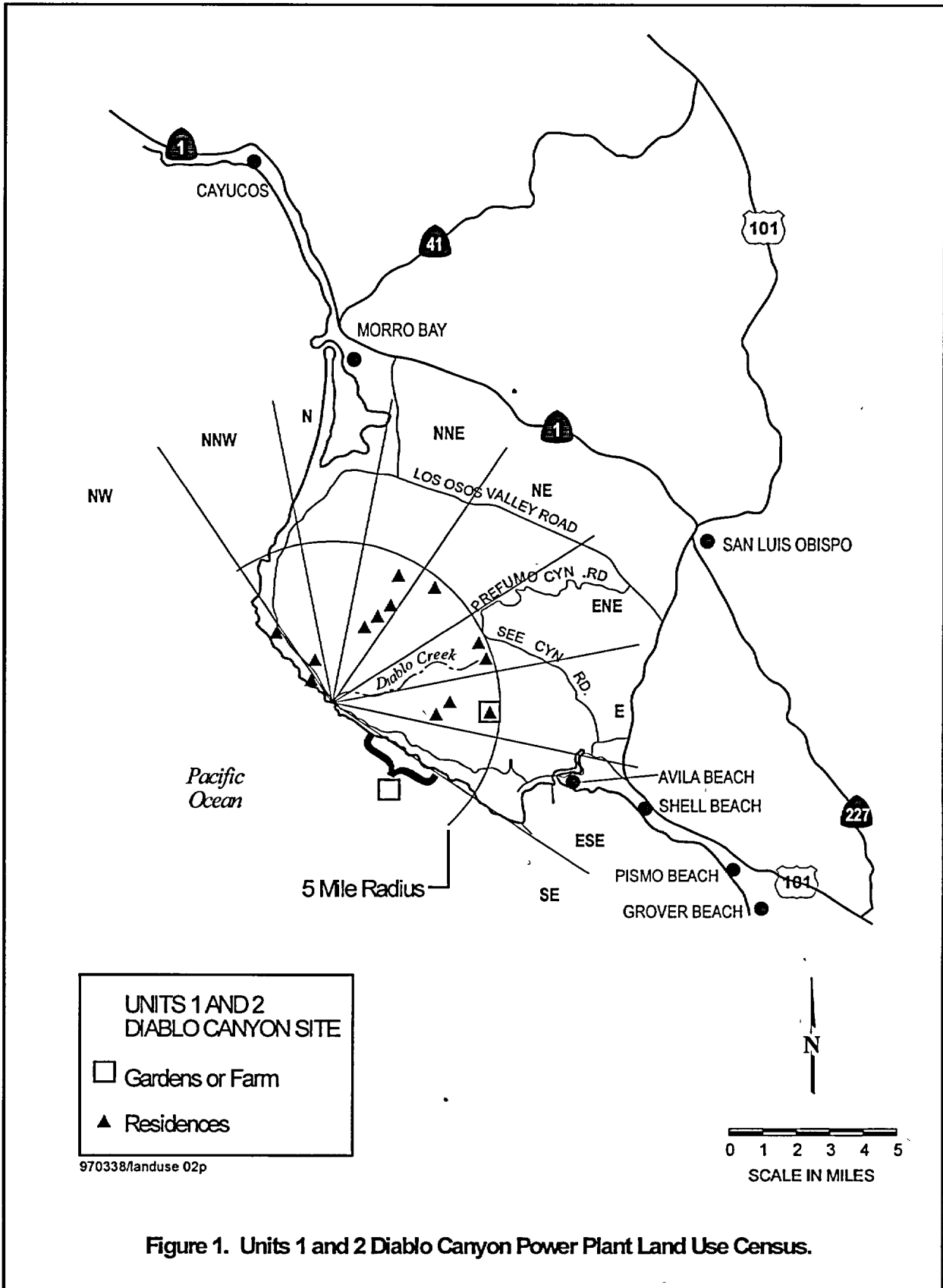

Figure 1. Units 1 and 2 Diablo Canyon Power Plant Land Use Census.