

# **PRACTICAL USER TIPS FOR ARCON96**

**10<sup>TH</sup> NUMUG MEETING  
Wilmington, NC June 2005**

**By Y. J. Lin  
Bechtel Power Corporation  
Frederick Maryland**



# History

- ARCON96, Rev. 1 was issued by the NRC in 1997 to calculate X/Qs in building wakes.
- NRC conducted a panel discussion for control room habitability analysis in March 2000 and suggested improvements to be made for ARCON96
- RG 1.194 was issued in 2003 to provide guidance on the proper use of ARCON96

# Area of Interest

- Release Mode
- Release Height
- Wind Direction
- Building Area
- Wind Speed

# Release Mode

- **ARCON96 offers 3 release modes (ground, vent, stack) but NRC only recognizes ground and stack releases;**
- **ARCON96 does not calculate plume rise;**
- **User could add plume rise to release height, but clear guidance was not provided - exactly what plume rise to be used?**
- **NRC suggests to treat vent releases as ground-level releases**

# Release Height

- ARCON96 calculates a “midpoint height” between the lower and upper wind instrument heights. The “midpoint height” is used to determine which level of the wind data are to be used in calculating  $X/Qs$ .
- Do not enter absolute heights even if you have treated a vent release as a ground-level release; the “midpoint height” approach could cause unexpected error. Suggest to always enter the actual release and receptor elevations.
- Both RG 1.194 and Users Guide (NUREG/CR-6331) do not discuss the use of the “midpoint height” approach.

**Figure A. Actual release and intake heights are used  
(Vent Release Height > Tower Midpoint Height)**

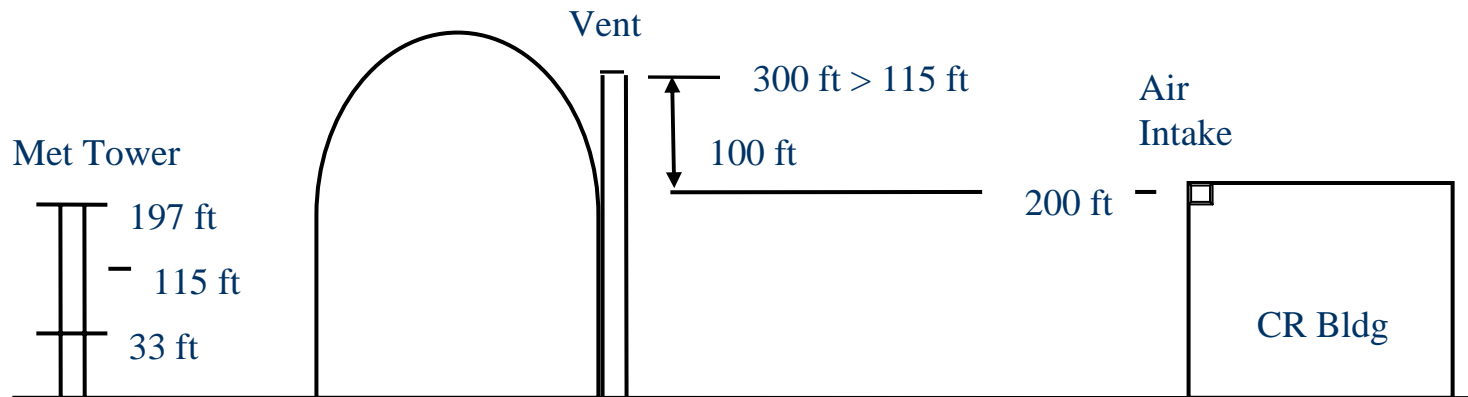

## Figure B. Absolute release and intake heights are used (Vent Release Height < Tower Midpoint Height)

Met Tower

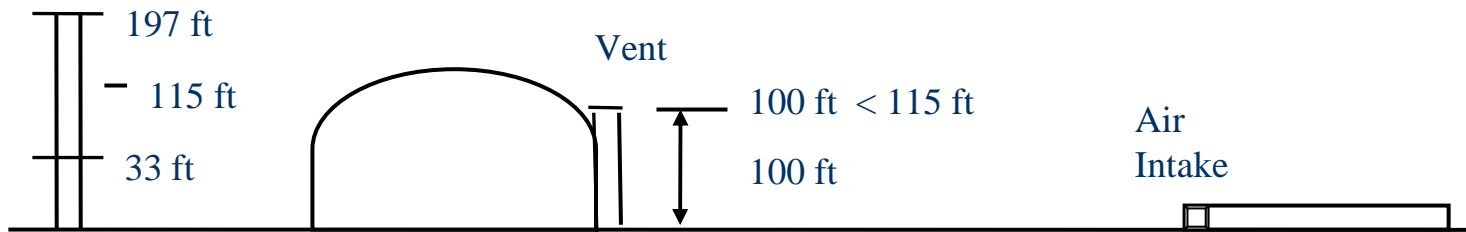

# Wind Direction

- ARCON96 defines valid wind directions as between 1 and 360 degrees; this approach is not the way meteorologists commonly used.
- ARCON96 treats 0-deg wind as calm.
- Users might need to change all the north wind direction to 360 degrees in their meteorological input data.



# Building Area

- In general, ARCON96 is not sensitive to the size building area.
- The worst case  $X/Q$ s usually occur under 3 to 4 m/s winds, instead of the 0.5 or 1 m/s winds when using the conventional Gaussian models.

# Wind Speed

- For a vent release (even if treated as a ground-level release as suggested by RG 1.194), ARCON96 assumes the wind speed at the release point is higher than that at the ground-level even the release point is located within the wake region.
- The above approach assumes that within the wake, higher level wind speeds are greater than the lower level winds. This assumption is questionable.
- The above issue is the consequence of using the “midpoint height” approach. The Users Guide or RG 1.194 needs to provide further explanation.

# Velocity Profiles In front and behind a Building

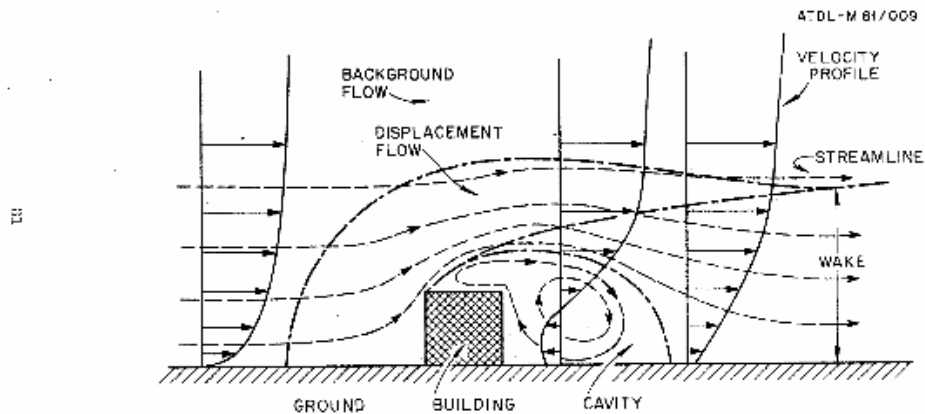

Figure 1. Simplified early model of centerline flow near a sharp-edged building normal to a deep boundary layer wind.

Source: Recommended Guide for the Prediction of the Dispersion of Airborne Effluents, 2nd Edition, ASME, 1973.

# SUMMARY

- **Always treat vent releases as ground-level releases, unless sound justification could be made;**
- **Always enter actual above grade heights for the vent release height and receptor height in modeling, instead of entering absolute heights;**
- **Make sure north winds are recorded as 360 degrees, instead of 0 degree in the input meteorological data set;**
- **The worst case ARCON96 calculated X/Qs usually occur under 3 to 4 m/s winds;**
- **ARCON96 is not sensitive to the building area when the wind speeds are low.**